

# User Manual

Release 1.6

## ECD-3

Electrochemical dilatometer



The information in this manual has been carefully checked and believed to be accurate; however, no responsibility is assumed for inaccuracies.

EL-Cell GmbH maintains the right to make changes without further notice to products described in this manual to improve reliability, function, or design. EL-Cell GmbH does not assume any liability arising from the use or application of this product.

**EL-Cell GmbH**

Tempowerkring 8

21079 Hamburg - Germany

**phone:** +49 40 79012-737

**fax:** +49 40 79012-736

**e-mail:** [info@el-cell.com](mailto:info@el-cell.com)

**web:** [www.el-cell.com](http://www.el-cell.com)

## Content

1	Product description .....	4
2	Features.....	7
3	Technical data .....	7
4	Safety Precautions.....	8
5	Unpacking.....	8
6	Start-up and disassembly.....	11
7	Assembling the cell inside the glove box .....	19
8	Further assembly outside the glove box.....	27
9	EC-Link Software Installation .....	31
10	Calibration and Settings.....	31
11	Recording the Displacement Signal with an External Potentiostat .....	31
12	Using the Reference Electrode .....	33
13	Using the valve .....	34
14	Choosing the appropriate spacer disc .....	35
15	Dilatometer Disassembly and Cleaning .....	36
16	Care Instructions .....	37
17	Consumables .....	37
18	Spare Parts.....	38
19	Connector and Cable Pin-out .....	44
20	Technical support.....	47
21	Warranty .....	47

## 1 Product description

The ECD-3 electrochemical dilatometer measures charge-induced strain (expansion and shrinkage) of electrodes down to the nanometer range. The ECD-3 has been mainly developed to investigate battery and other insertion-type electrodes. It may, however, also be used for many other electrochemical systems utilizing aprotic organic electrolyte solutions. The electrode materials can be either bound film or single crystals/grains (e.g., graphite flakes). The maximum sample size is 10 mm x 1 mm (diameter x thickness).

The heart of the ECD-3 is an electrochemical cell, hermetically sealed against the ambient atmosphere. The two electrodes inside are separated by a stiff glass frit. The upper working electrode (**WE**) is sealed using a thin metal foil, through which any charge-induced thickness change is transmitted toward the sensor/load unit above. This working principle allows determining the height change of the working electrode without any interference from that of the counter electrode (**CE**).

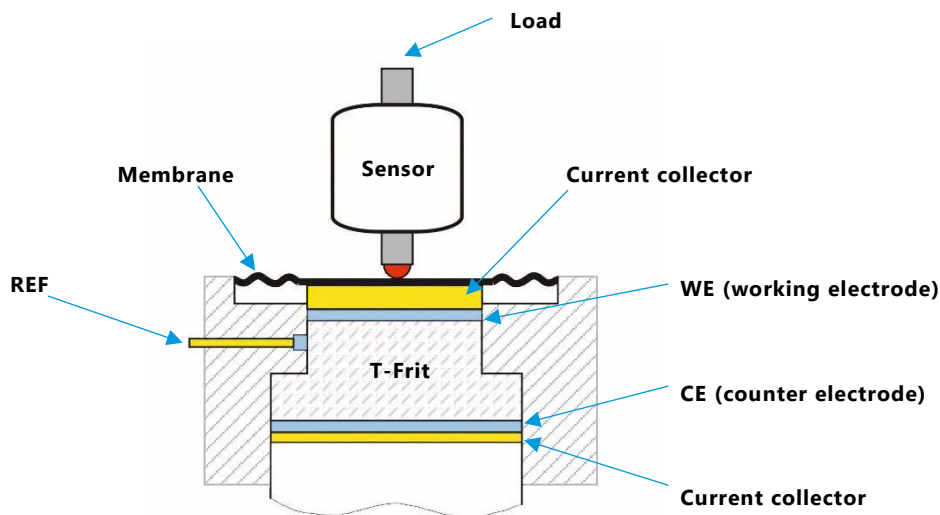

A high-resolution displacement (LVDT) transducer detects dimensional changes of the WE ranging from 100 nanometers up to 500 micrometers during the same experiment that may last a few minutes to many days.

The ECD-3 features an integrated USB data logger for recording the electrode displacement, temperature, cell potentials, and current. Analog outputs of displacement and temperature are provided for integration with external instruments.

The dilatometer will be operated inside a temperature-controlled chamber for best accuracy and drift stability.

### The basic structure of the ECD-3:

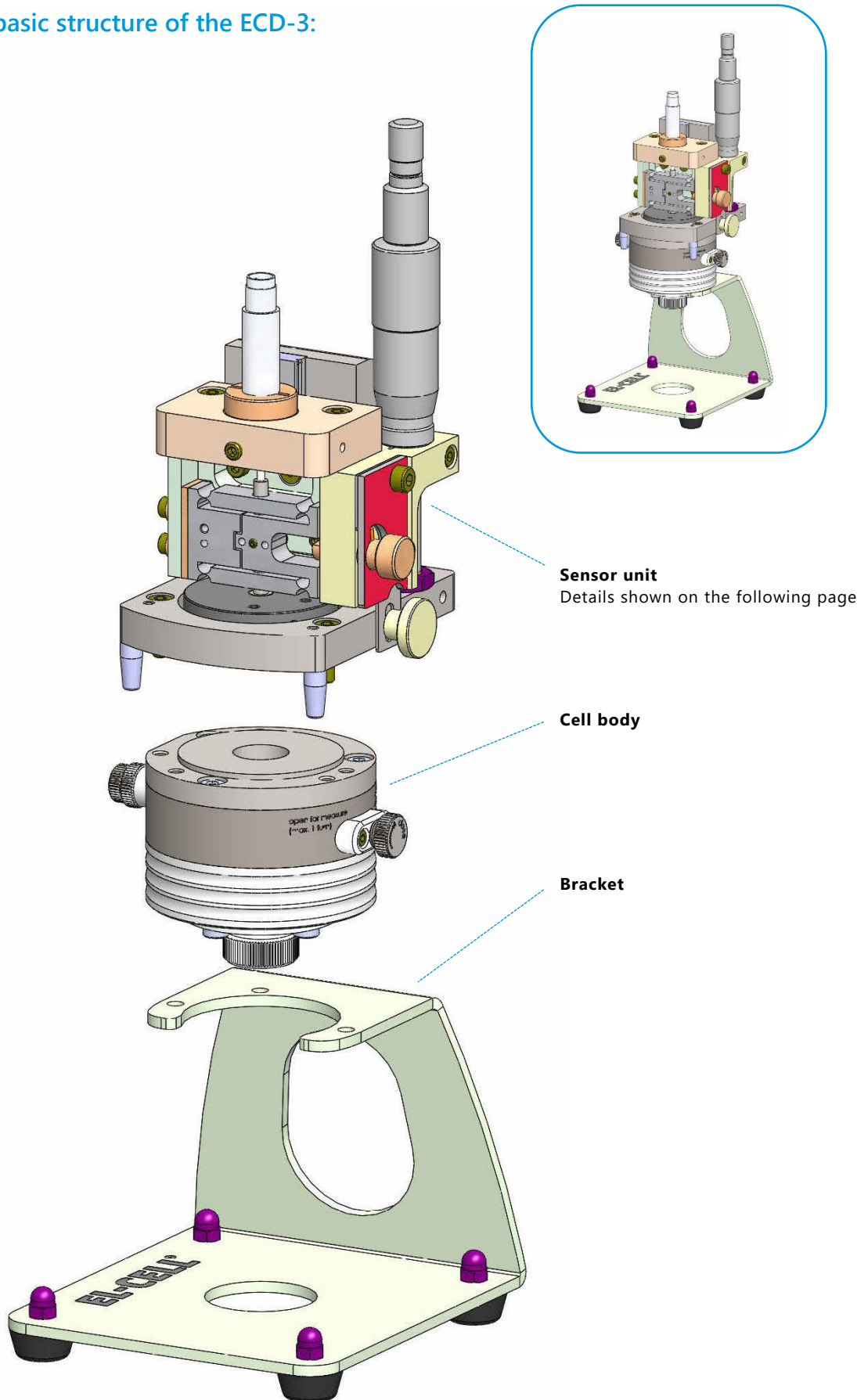

Cut drawing of the ECD-3:

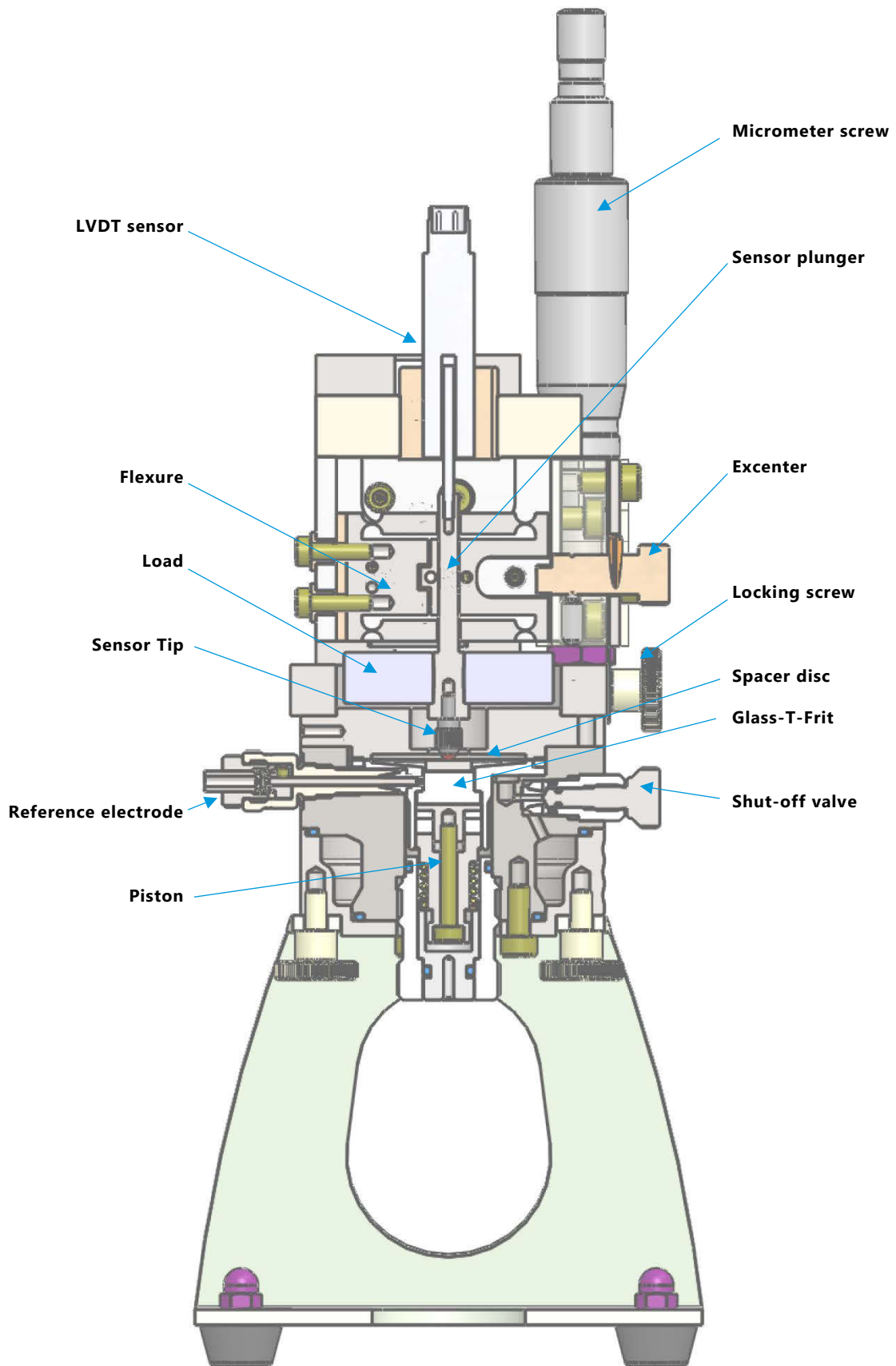

## 2 Features

The ECD-3 is an electrochemical dilatometer for measuring changes in the thickness of the working electrode of a battery test cell. The main features of the ECD-3 are briefly described in the following:

- LVDT sensor system with <math><50\text{ nm}</math> resolution, drift stability of <math><100\text{ nm/hour}</math> (sample-free instrument at constant temperature), and <math>500\text{ }\mu\text{m}</math> full range.
- Conditioning electronics with analog output signals (-10 to 10 V) for displacement and temperature.
- Integrated USB data logger for recording displacement, temperature, cell potentials, and current.
- 3-electrode electrochemical cell
- Materials in contact with electrolyte: PEEK, borosilicate glass, stainless steel 316L for aprotic, gold for aqueous electrolytes

## 3 Technical data

- Working (upper) electrode: bound electrode film or single crystal/grain; max. sample size 10 mm x 1 mm (diameter x thickness)
- Counter (lower) electrode: 12 mm diameter
- Load on a working electrode: 1 N
- Electrolyte volume: approx. 0.5 ml
- **Operating temperature range:** Cell and sensor: -20 to +70 °C;  
Conditioning electronics and data logger: 0 to +40 °C

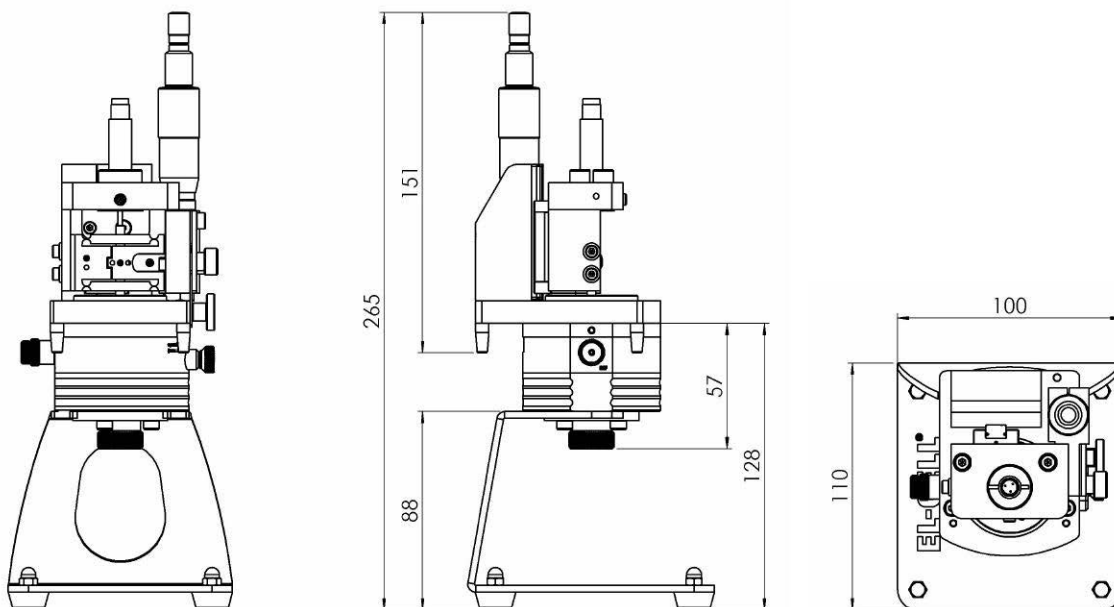

All measurements in mm

## 4 Safety Precautions

Use proper safety precautions when using hazardous electrolytes. Wear protective glasses and gloves to protect you against electrolytes that may accidentally spill out of the instrument during filling, operation, and disassembly.

## 5 Unpacking

Check the contents of the packages against the list given below to verify that you have received all of the required components. Contact EL-CELL if anything is missing or damaged.

**NOTE:** Damaged shipments must remain within the original packaging for freight company inspection.

### List of Components:



1. ECD-3 dilatometer [ECD3-00-0001-A](#), assembled
2. Box ECD-3 [ECE1-00-0006-E](#), assembled
3. ECD sensor cable [ECE1-00-0036-A](#)
4. ECD-3 cell cable [ECE1-00-0033-F](#), assembled
5. Power supply 15W/24V DC [ELT9045](#)
6. Power supply adapter [ELT9078](#)
7. USB cable type A/B (2.0 m) [ELT9167](#)





- 8. USB stick containing EC-Link data logger software [ECE1-00-0052-B](#)
- 9. Allen wrench 2.5 mm [WZG9059](#)
- 10. Allen wrench 3 mm [WZG9058](#)
- 11. 3 x PE Seal II ECD-3 piston [ECC1-01-0044-D](#)
- 12. 3 x PTFE Seal ECD-3 piston [ECC1-00-0044-C](#)
- 13. 1 x PTFE Seal ECD 33.3 x 1.8 mm (3 pcs.) [ECC1-01-0043-D/3](#)
- 14. 3 x O-Ring 33 mm x 1.78 mm [DIC9034](#)
- 15. 3 x O-Ring 50.5 mm x 1.78 mm [DIC9038](#)
- 16. T-Frit 10/12.5 [ECC1-00-0041-B](#)
- 17. Stiff Plate [ECD1-00-0041-A](#)
- 18. 3 x Ferrule 1.5 mm (short top part) [ECC1-00-0029-H](#)
- 19. Membrane (aprotic) 1.4404 [ECC1-00-0019-D](#)
- 20. Spacer disc Set 2.1 – 2.7 mm (3 pcs) [ECC1-01-0374-AF](#)
- 21. Separator (GF/A) 12 mm x 0.26 mm (10 pcs) [ECC1-01-0012-Q/X](#)
- 22. Demonstration kit for ECD [ECD1-00-0900-A](#)

- 23.** Allen wrench set (0.9 / 1.3 / 1.5 / 2) (4 pcs) [ECC1-01-0028-A](#)
- 24.** Open end wrench AF7 [ECC1-09-2037-A](#)
- 25.** Disassembly device piston [ECC1-09-3048-A](#)
- 26.** Allen screwdriver 2.5 mm [WZG9003](#)
- 27.** Spherical Allen screwdriver 3 mm [WZG9002](#)
- 28.** Tweezer antiacid / stainless [WZG9001](#)

## 6 Start-up and disassembly

Follow the same procedure beginning at step 3 when disassembling the instrument after completing an experiment.

**General advice:** Practice the assembly procedure outside the glove box with dummy components before going for the experiment. Make sure you have understood the how and why of every single step. Ask us otherwise.

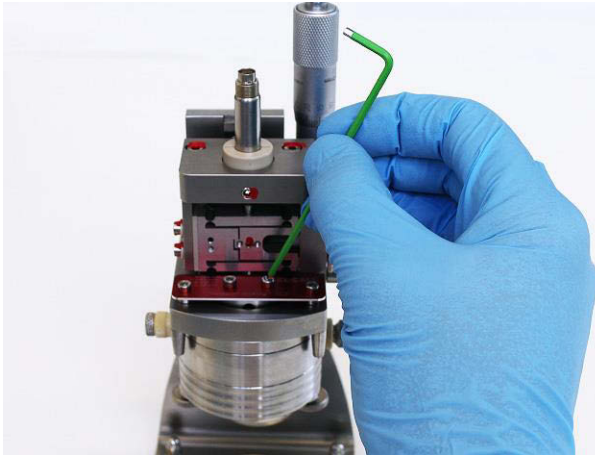

**6.1** After unpacking the ECD-3, remove the transport lock from the sensor unit.

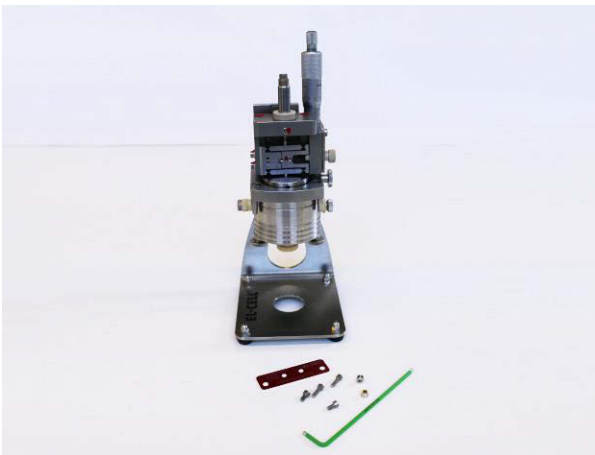

**6.2** Unscrew the two inner screws first, only then the two outer screws.

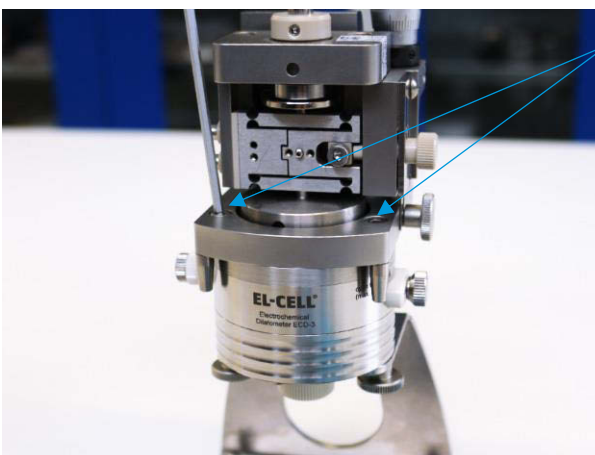

**6.3** Unscrew and detach the sensor unit.



6.4 Screw off the cell body from the bracket.



6.5 Unscrew the spring load from the cell body.



6.6 Unscrew the reference electrode.

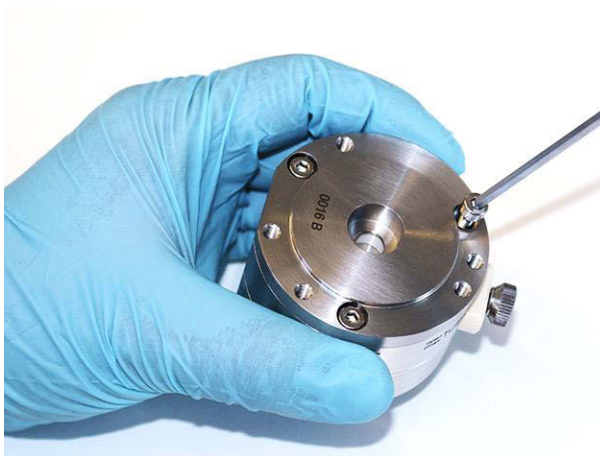

6.7 Remove the cover flange.

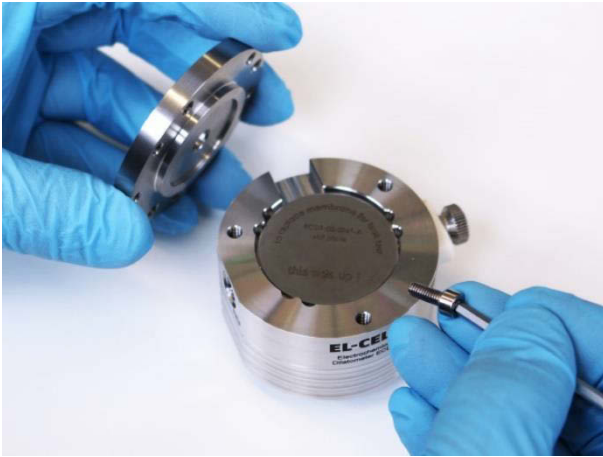

**6.8** When disassembling the dilatometer for the first time, remove the stiff plate below the cover flange. This plate is for transport only. For the actual experiment, replace the plate by the provided metal membrane.

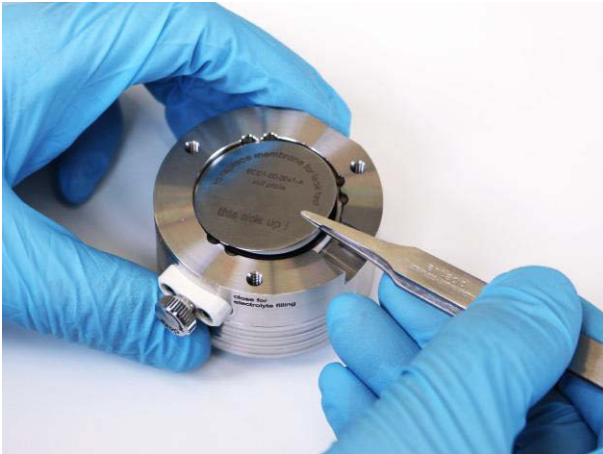

**6.9** Remove the stiff plate or membrane from the cell body

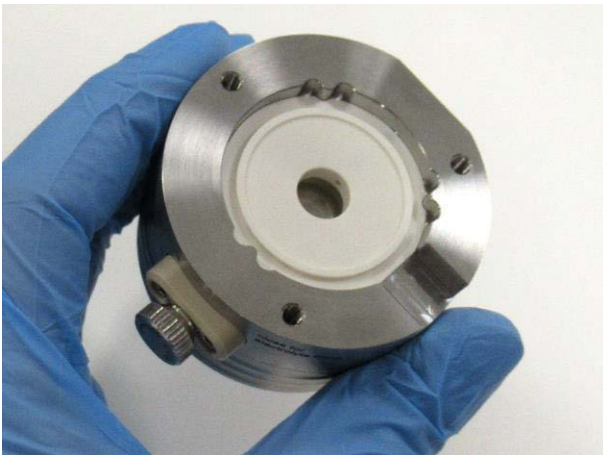

**6.10** Now the frit flange with the PTFE-Seal and the piston in the middle are visible.



**6.11** Pull the frit flange out of the cell body.



**6.12** Loosen the socket screw at the end of the piston a little with the Allen wrench (half turn). This releases the disk springs inside piston and allows it to be pulled out.



**6.13** Pull the piston out of the frit flange by using the dedicated removal tool.

To do this, first, screw the two halves of the tool together.



**6.14** Insert the frit flange with inserted piston from below.



**6.15** Slide the locking disc completely over the tool as shown in the picture.

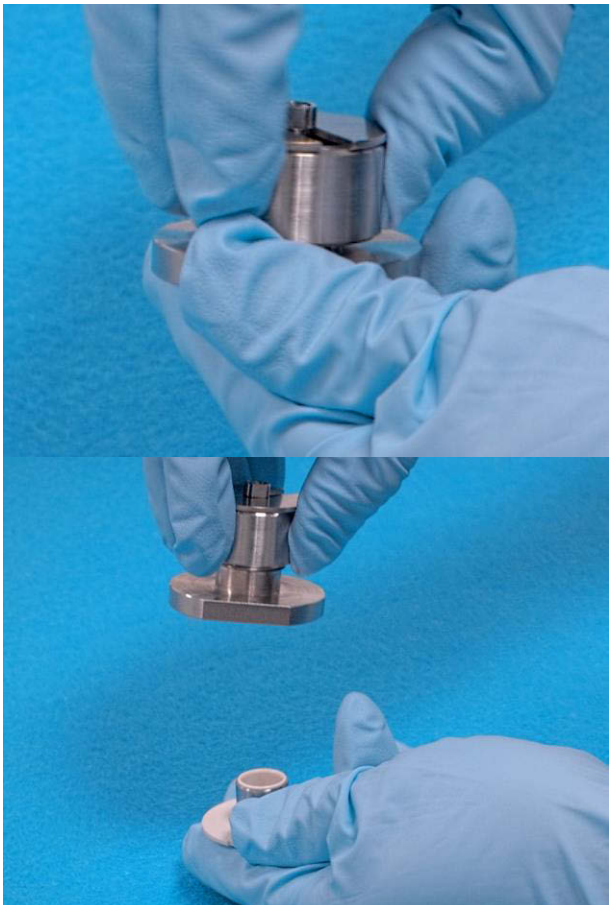

**6.16** Unscrew the tool to remove the piston from the frit flange.

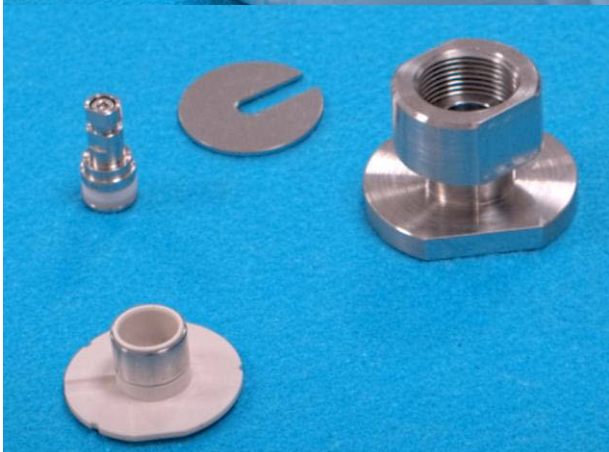

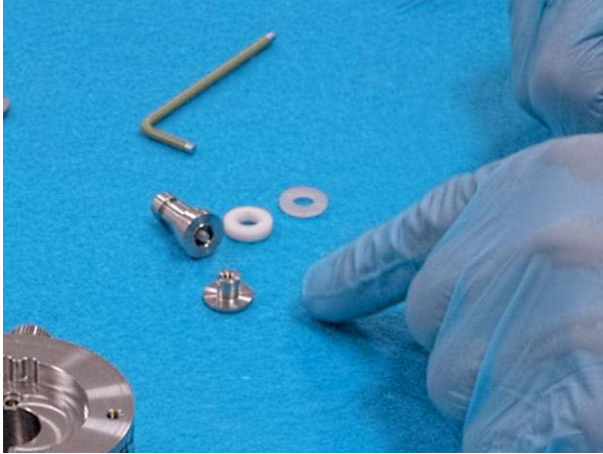

**6.17** Remove the socket screw at the end of the piston and disassemble it. Both seals need to be renewed before each test.



The following steps 6.18 to 6.20 describe the disassembly of the base body, dead volume cover, and dead volume valve. The dead volume option is no longer used with the updated version of the dilatometer. Therefore, leave those parts in the assembled state. The valve does not need to be installed.



**6.18** Remove the dead volume cover and both O-rings.

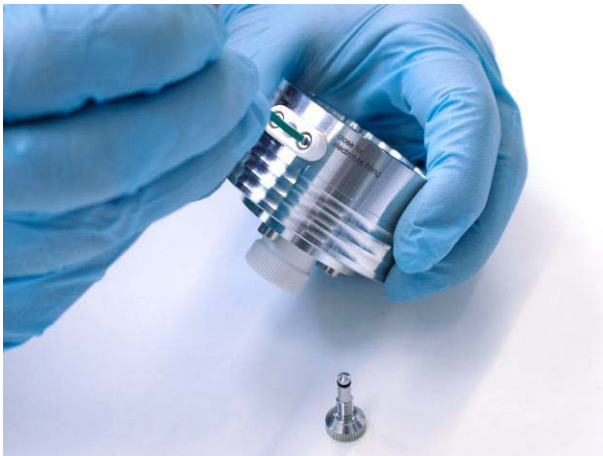

**6.19** Unscrew the valve stem and the valve body.



**6.20** Remove the three screws that fix the dead volume cover.

With the updated version (2022) of the dilatometer, the dead volume and valve (comprised of items 5, 6, 11, 12, 15, and 16) can always be left in the assembled state. There is no need for cleaning and drying these parts before use. The valve does not need to be installed.

All other parts must be dried before moving into the glove box for assembly. Recommended drying conditions: 80°C, <0.01 mbar, 12 hours.

NOTE: For highly moisture-sensitive systems, we recommend drying the glass frit separately at a higher temperature: 180°C, <0.01 mbar, 12 hours.

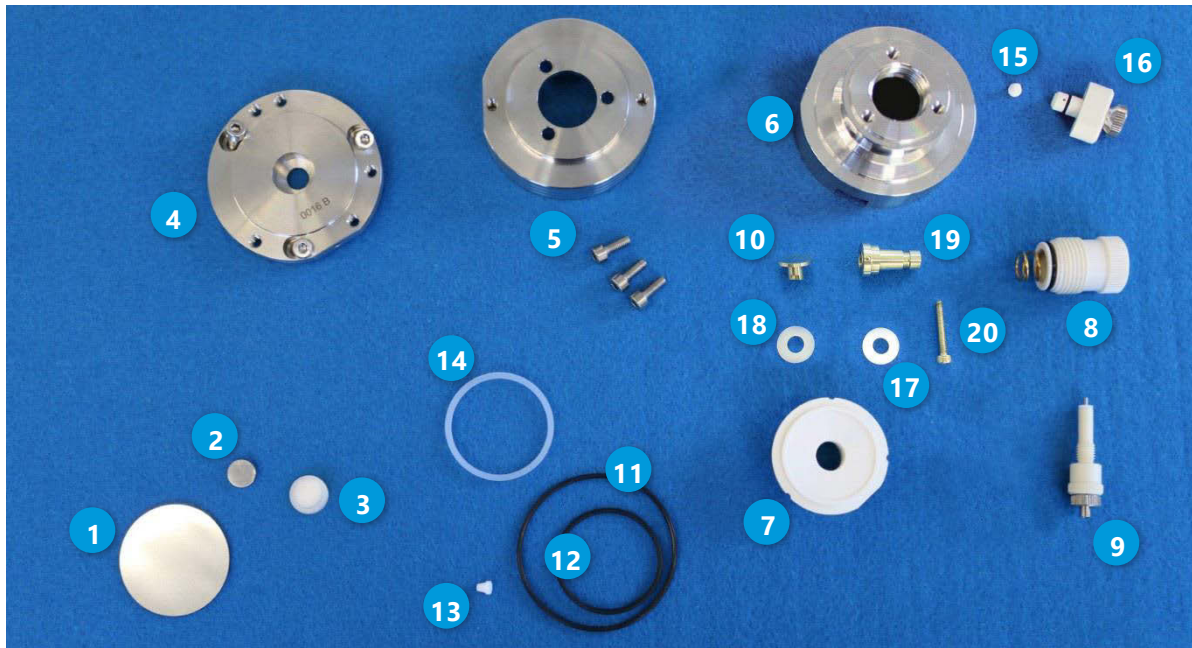

- |   |  |
|---|--|
| <b>1.</b> Membrane (aprotic) 1.4404   | <b>11.</b> O-Ring 50.5 x 1.78 mm, EPDM   |
| <b>2.</b> Spacer disc (proper thickness depends on working electrode thickness) | <b>12.</b> O-Ring 33.05 x 1.78 mm, EPDM  |
| <b>3.</b> T-frit  | <b>13.</b> Socket screw  |
| <b>4.</b> Cover the flange with three screws                                    | <b>14.</b> PE-Seal for ECD-3 (33 mm x 1.6 mm)  |
| <b>5.</b> Dead volume cover with three screws                                   | <b>15.</b> Ferrule 1.5 mm, PTFE  |
| <b>6.</b> ECD-3 base body   | <b>16.</b> Shut-off valve ( <b>Note:</b> Not used with the updated version of the dilatometer) |
| <b>7.</b> Frit flange   | <b>17.</b> PTFE Seal ECD-3 piston  |
| <b>8.</b> Spring load   | <b>18.</b> PE Seal II ECD-3 piston   |
| <b>9.</b> Reference electrode   | <b>19.</b> Thrust screw VII (ECD-3)  |
| <b>10.</b> Piston PTFE-sealing, internal thread (ECD-3)                         | <b>20.)</b>  |

## 7 Assembling the cell inside the glove box

After moving the different parts of the disassembled cell body into the glove box, follow the steps below. Protect yourself and handle the chemicals with care.

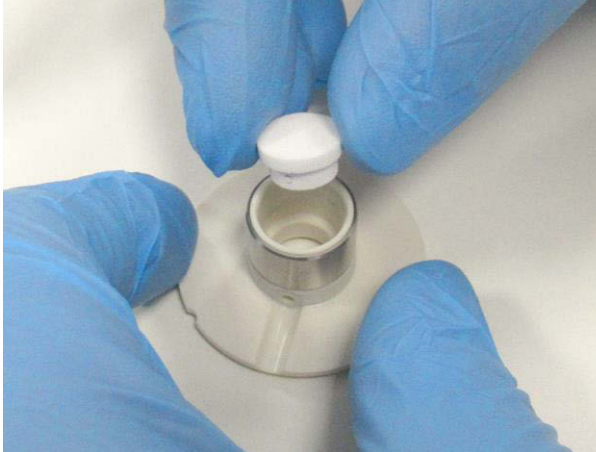

**7.1 Inside the glove box:** Insert the T-frit with the smaller side pointing downwards into the frit flange.

**Note:** Make sure that the inside of the frit flange does not get damaged/ scratched when inserting the T-frit. Replace the frit flange as necessary.



**7.2 Inside the glove box:** Put a glass fiber separator (12 mm diameter) on top of the frit

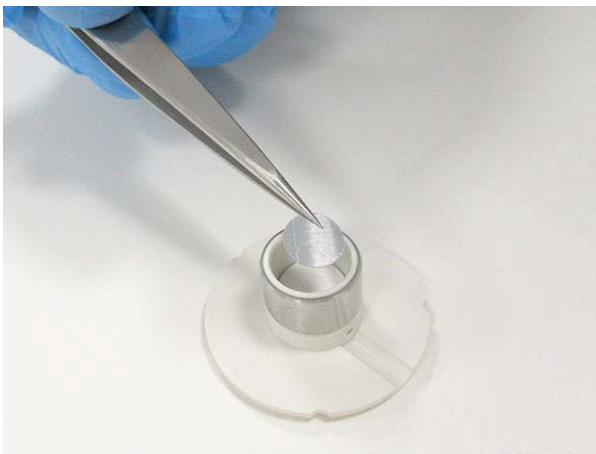

**7.3 Inside the glove box:** Insert the lithium metal counter electrode.



**7.4 Inside the glove box:** First place the PE sealing (PE Seal II ECD-3 piston) followed by the PTFE sealing (17.PTFE Seal ECD-3 piston) on the piston. The outward curved side of the sealing rings must face away from the piston (see sketch below)

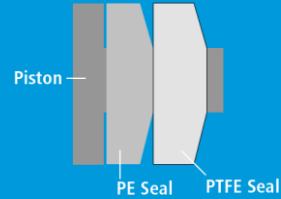

**7.5 Inside the glove box:** Add the thrust screw.

Align it so that the mark on the thrust screw is centered on the recess in the piston.



**7.6 Inside the glove box:** Tighten the socket screw gently with the provided allen wrench.



**7.7 Inside the glove box:** Attach the counter piston from below. Use the removal tool to push it. The piston must be pressed into the frit flange until the two sealing rings are no longer visible.

Make sure that it is positioned straight in the frit flange.



**7.8 Inside the glove box:** Tighten the socket screw at the end of the piston firmly using the tools provided.

**Important note:**

**Only use a frit flange with an attached metal support ring as shown in the picture. Otherwise the frit flange may be damaged when trying to tighten the screw!**



**7.9 Inside the glove box:** Put this assembly into the cell base body. Make sure that the two grooves at the frit flange and the cell base body are properly aligned.

**Note:** Make sure that the frit flange is fully inserted. You may otherwise damage the cell.

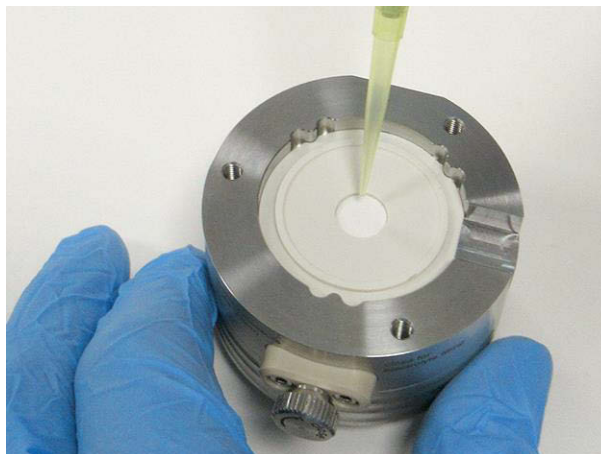

**7.10 Inside the glove box:** : Add 320-420  $\mu$ l of electrolyte using a pipette.



**7.11 Inside the glove box:** : Place the working electrode with the active side pointing downwards on top of the T-Frit.



**7.12 Inside the glove box:** : Insert the PTFE seal, make sure it is inserted correctly.



**7.13 Inside the glove box:** Put the spacer disc on top of the electrode, make sure that it is placed in the center of the electrode. The proper spacer disc thickness depends on the working electrode thickness, see chapter 14.



**7.14 Inside the glove box:** Then put the membrane on top.



**7.15 Inside the glove box:** Hold the pushbutton on the reference pin pressed and pick up some lithium with the reference pin. Make sure that the hole of the reference pin is completely filled with lithium metal. Incomplete filling may result in scatter/ noise of the WE potential. Make sure that the reference pin and the PTFE ferrule are not corroded or damaged. The PTFE ferrule must be white and must not show any black coloration. Replace if necessary.

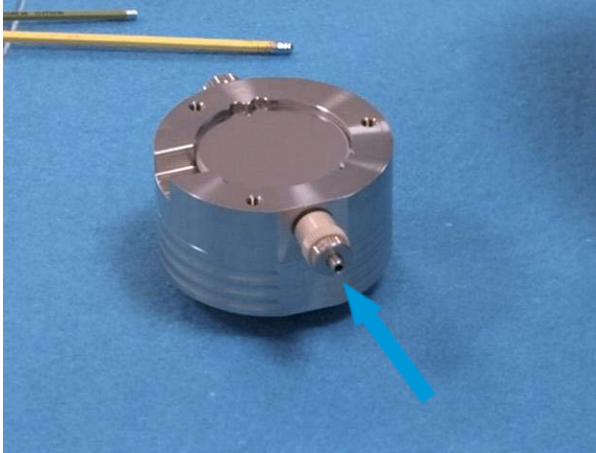

**7.16 Inside the glove box:** Attach the reference pin gently to the cell body.

Push onto the back of the reference pin while screwing it in.



**7.17 Inside the glove box:** Attach the cover flange.

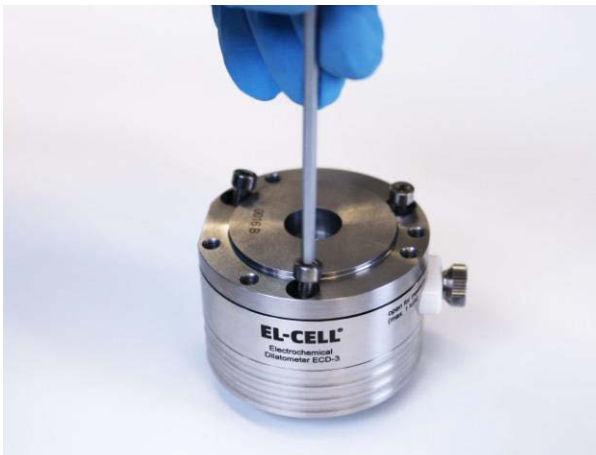

**7.18 Inside the glove box:** Now close the cell body with the three cover screws. In the first step, tighten the screws slightly with the enclosed screwdriver.





**7.19 Inside the glove box:** After that, we recommend using the allen key to tighten the screws in small increments on all three sides until they reach the stop.



**7.20 Inside the glove box:** Then check that the cell cover is firmly seated on the housing and that no gap is visible.



**7.21 Inside the glove box:** Now tighten the reference pin firmly.



**7.22 Inside the glove box:** Now screw in the spring load into the cell base.



**7.25 Inside the glove box:** The cell is now assembled and hermetically sealed, and can be removed from the glove box.

## 8 Further assembly outside the glove box



**8.1** Hook the assembly into the bracket and fasten it with the two knurled screws.

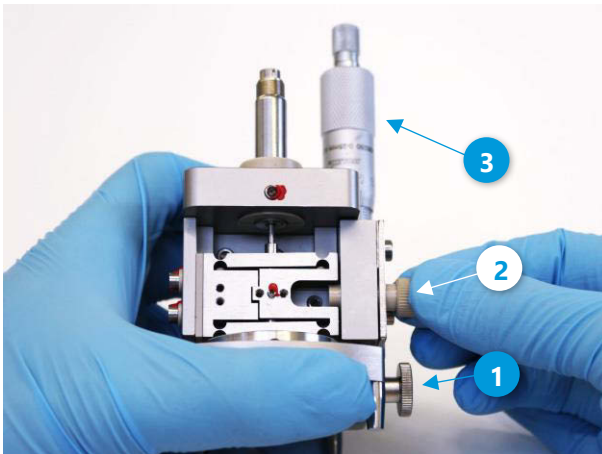

**8.2** Unlock the locking screw (1) and the excenter (2). Then turn the micrometer screw (3) clockwise until the sensor tip is in the upmost position.

**Note:** Not following the above instruction may result in damage of the membrane, the glass frit, or even the sensor unit, when attaching the sensor unit onto the dilatometer cell.



**8.3** Attach the sensor unit onto the dilatometer cell.

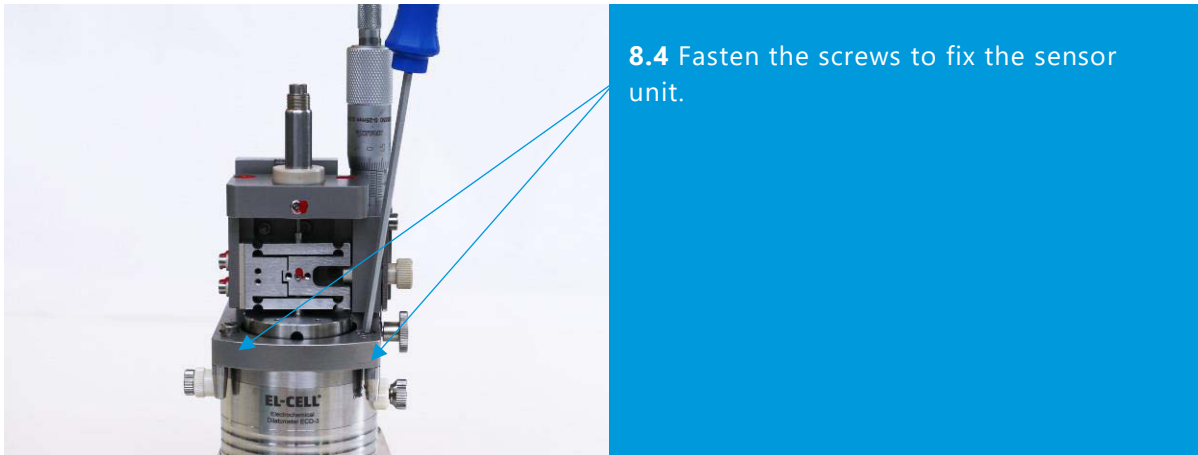

Then connect all cables as shown in the photo below. We highly recommend operating the dilatometer in a temperature-controlled environment.

- 1. ECD-3 cell cable
- 2. ECD sensor cable
- 3. Power supply + power supply adapter
- 4. USB cable
- 5. Example: Individual Biologic data logger cable (available on request)

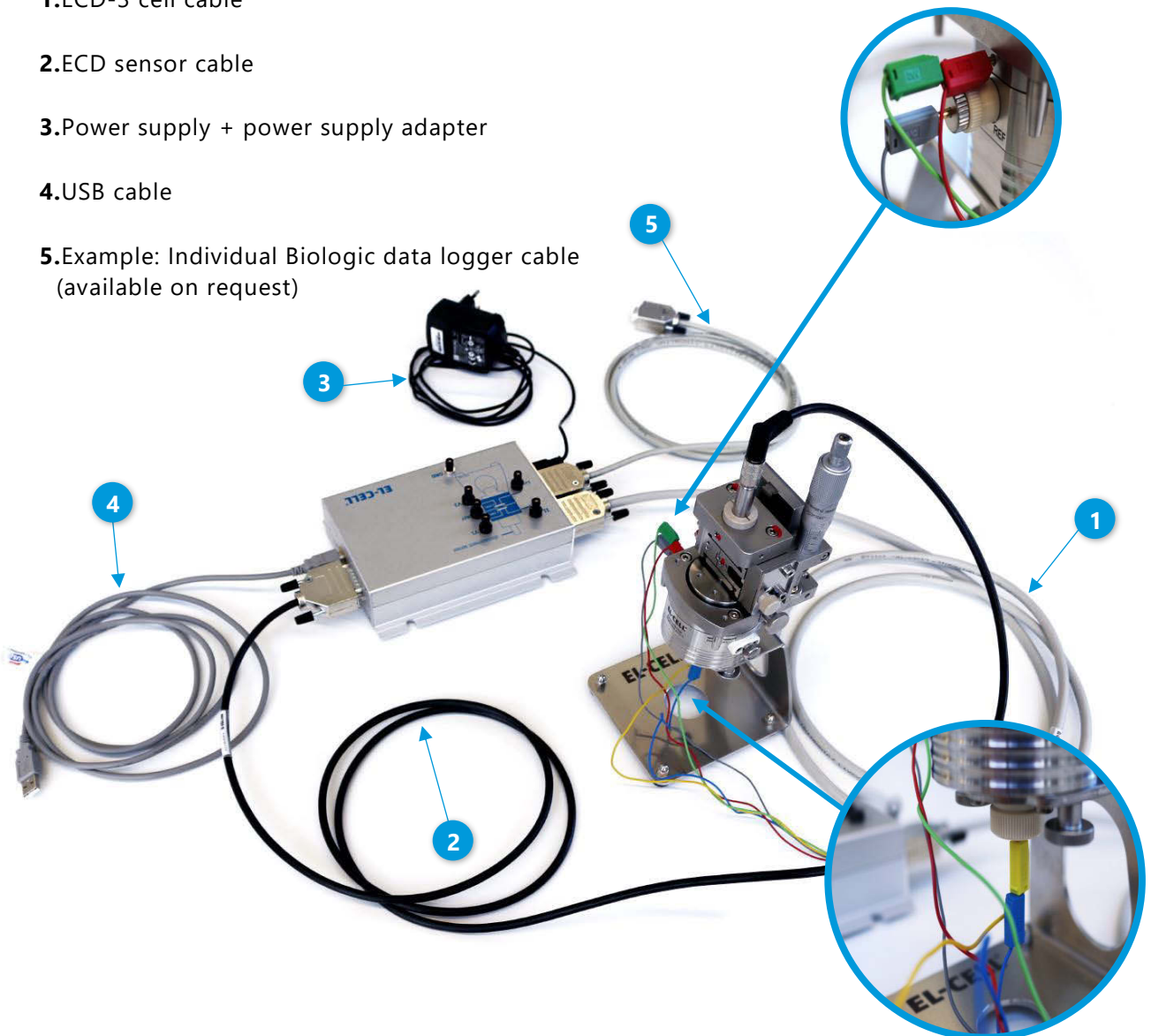



**8.5** Unlock the locking screw (1) and the excenter (2), if not already done.



**8.6** Lower the sensor tip by turning the micrometer screw counter-clockwise.

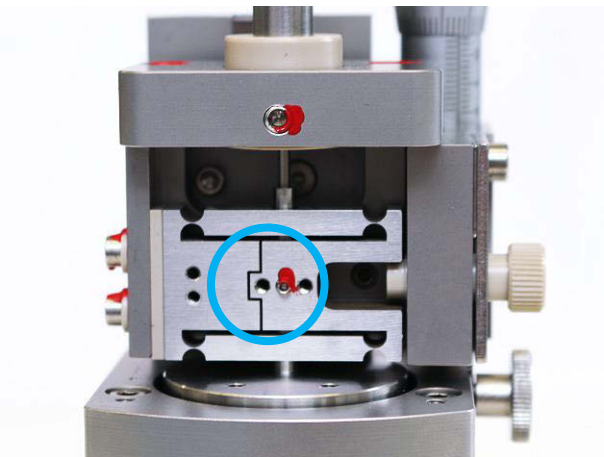

**8.7** The sensor position is indicated by the LED bar graph indicator at the electronic box of the ECD-3. Any yellow LED indicates a valid position.

For best accuracy and resolution, adjust the sensor approximately in central position.



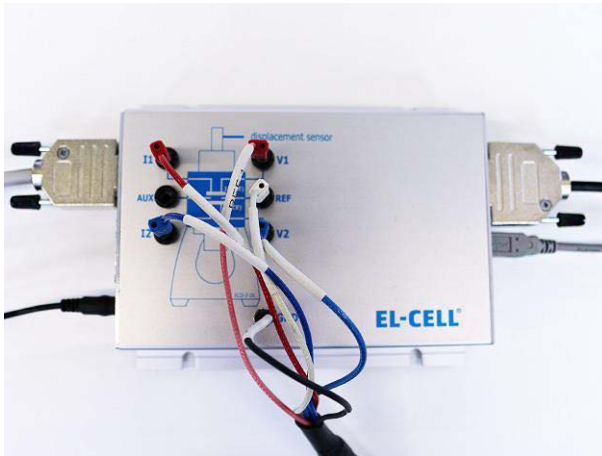

**8.8** Example: Connecting a Biologic data logger cable (available on request). View the whole wiring on page 28.

Finally, connect your potentiostat or battery tester to the 4 mm jacks on the front panel of the controller box. Make sure that both instruments share a common ground (GND) potential. Almost any potentiostat or battery tester can be used. The rightmost column in the table below refers to the example of using a Biologic potentiostat (MPG-2, SP, VSP and VMP series).

Controller Box	Potentiostat	Biologic Potentiostat, VSP, VMP3, etc.
I1	WE Current	WE
V1	WE Sense	Ref1
REF	Reference	Ref2
V2	-	Ref3
I2	CE	CE
GND	GND	GND

Before starting the electrochemical cycle, we recommend holding the cell at constant potential (or open-circuit) for several hours to allow for baseline stabilization. The initial rest period helps discern charging-induced dimensional changes from the initial creeping.

**NOTE:** All materials display a more or less pronounced creeping. They tend to shrink when applying a load and swell when removing it. A significant contribution to the initial creeping seen right after cell assembly is to be assigned to the construction materials of the dilatometer. Creeping of the working electrode is induced each time the mechanical properties of the working electrode are altered by charging. Therefore, each charge-induced height change is followed by some creeping. The charge-induced creeping effects are real and not artifacts of the measurement.

## 9 EC-Link Software Installation

To record the displacement signal together with the cell voltage, cell current, electrode potential and temperature, the software of the integrated data logger needs to be installed on a Windows® PC.

- You must be logged in to an account with Administrator privileges.
- Save your work and close down all active programs.
- On the installation media, run **CDM\*\_Setup**. This will install the FTDI driver required to establish the USB connection with the data logger.
- On the installation media, run **Setup**. This will install the EC-Link data logger software. Follow any instructions that may appear on your screen.
- Once installation is finished plug the provided USB cable into the host PC and the ECD-3 controller box.
- Launch the EC-Link data logger software if not already done.
- After a few seconds, EC-Link should report a valid connection and you are ready to start the measurement.

Additional information on the EC-Link software can be found in a separate manual (<https://el-cell.com/support/manuals>).

## 10 Calibration and Settings

Calibration of the instrument has been carried out at the factory. The corresponding settings of the EC-Link software are stored in the file **Settings\*.V2** in the installation directory on the local hard drive and the installation media. If the default settings have been changed for any reason, the original settings can be restored by copying **Settings\*.V2** from the installation media into the installation directory of the EC-Link software.

## 11 Recording the Displacement Signal with an External Potentiostat

Many of today's battery testers and potentiostats provide additional analog inputs that may be used to record sensor signals along with cell current and potential.

The following combination of the ECD-3 with a Biologic potentiostat (MPG-2, SP, VSP and VMP series) is described as an example. The Biologic potentiostats feature two analog inputs used here to record displacement and temperature.

1. Connect the 9-pin Sub-D connector of the optional analog output cable to the analog input of the respective VMP3 channel.
2. In the Biologic EC-Lab software, load the experiment settings ECD\*.mps provided on the ECD-3 installation media. The settings are shown in the External Devices dialog. Adapt the Parameter Settings of the charge/ discharge protocol to your particular experiment, if necessary.



## 12 Using the Reference Electrode

The reference electrode assembly comprises a metal pin with a blind bore at the end pointing to the glass frit. The user must fill the blind bore with the reference material before attaching the reference assembly to the cell body. For most aprotic lithium chemistries, lithium metal is a proper reference material. For aprotic supercap electrolytes, PTFE-bound activated carbon may serve as a (pseudo) reference material.

To make sure that, in the assembled state, the reference material is pressed against the glass frit of the cell stack, it is advised to push onto the back of the reference pin while screwing in the pin.

### NOTES:

- Avoid any direct contact of the PTFE ferrule with lithium metal. PTFE is being reduced to (black and porous) carbon when getting in contact with lithium.
- Renew the PTFE ferrule after each experiment.
- The standard dilatometer comes with a stainless steel reference pin, which is good for use with lithium metal. In contrast, the gold reference pin, which is part of the optional aqueous kit, must not be used with lithium metal. Gold and lithium spontaneously alloy when getting into contact with each other.

### Components of the reference electrode:

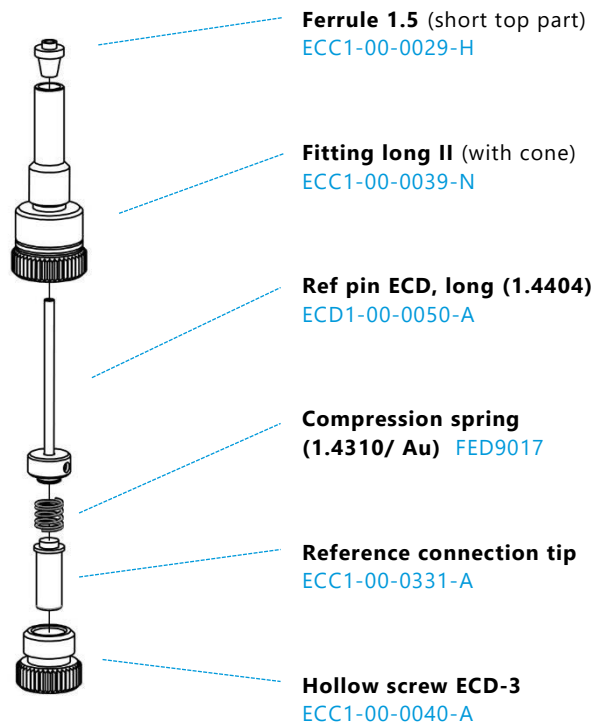

## 13 Using the valve

**The shut-off valve is no longer used in the updated version (2022). The following points refer only to the case where you want to use the instrument in the old configuration with dead volume.**

The shut-off valve makes or breaks the connection between the cell volume and the dead volume of the dilatometer when using a specialized frit flange. When running the experiment, the valve should be open. This way, unwanted pressure build-up via gas evolution is effectively mitigated.

### NOTES:

- Close the valve gently by hand. Excessive torque may damage the valve.
- Some valve parts may get into electrolyte contact. Therefore, it is advised to unscrew the valve seating and stem after use. The two O-ring seals and the PTFE ferrule may stay in place. Wash with plenty of water or other appropriate solvents.
- Dry the valve parts in the disassembled state (80°C, vacuum, overnight) before reassembly inside the glove box.

## 14 Choosing the appropriate spacer disc

To achieve electrical contact between the electrode and the membrane, it is essential to fill the 2.7 mm gap between the T-Frit and the Membrane. This is achieved by the stack comprised of the spacer disc (current collector) and the working electrode.

Choose a proper spacer disc height depending on the thickness of your electrode. Spacer discs are available in different heights ranging from 0.9 mm to 2.7 mm in 0.1 mm steps; for a complete list see page 37. If in doubt choose the next higher spacer disc. We recommend using the 2.7 mm spacer disc for all electrodes in the thickness range of 0 to 150  $\mu\text{m}$ .

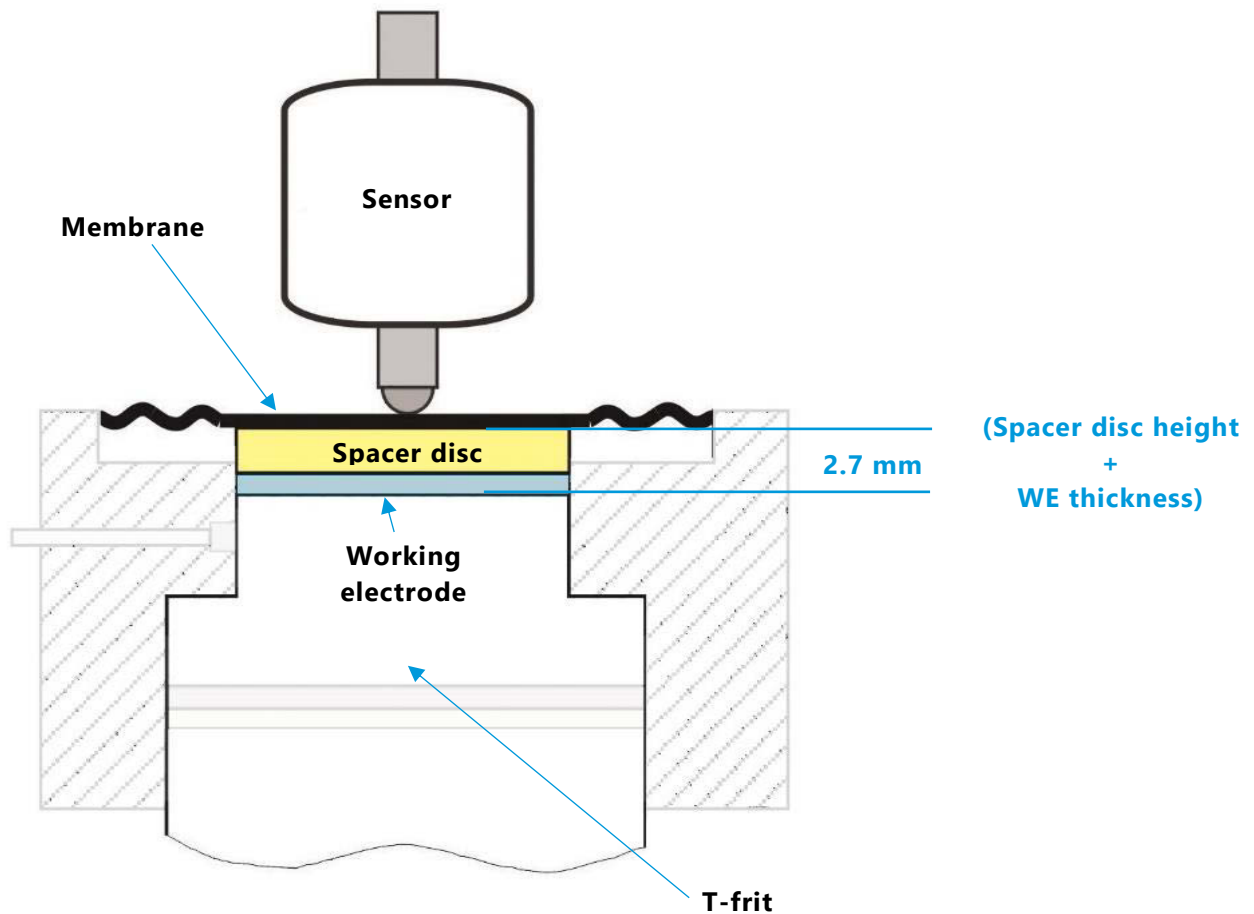

## 15 Dilatometer Disassembly and Cleaning

**When disassembling the dilatometer cell, wear protective gloves and glasses.**

Collect parts that have been in contact with electrolytes on a separate tray for subsequent cleaning.

1. Disconnect all cables from the dilatometer cell and the sensor unit.
2. Remove the dilatometer cell from the temperature chamber.

Then follow the instructions described in chapter 6, starting at step 3.



Clean all wetted parts right after disassembly. Ultrasonic cleaning with water and/or detergent wash is recommended. Valves and tubing may clog if not purged adequately with water or another solvent.

After cleaning, dry all parts at 80°C in a vacuum (<0.1 mbar) overnight. See page 18 for a list of all parts that need to be dried.

## 16 Care Instructions

Upon assembly, ensure that the reference pin and the PTFE ferrule are not corroded or damaged. The PTFE ferrule must be white and must not show any black coloration.

**We strongly recommend replacing all o-rings, sealings and ferrules before each test.**

## 17 Consumables

### Cell Body:

- T-Frit 10/12.5 (5 pcs) [ECC1-00-0041-B/V](#)
- Membrane (aprotic) 1.4404 (3 pcs) [ECC1-00-0019-D/3](#)
- O-Ring 33.05 x 1.78 mm (10 pcs) [DIC9034/X](#)
- Ferrule 1.0 (10 pcs) [ECC1-00-0029-B/X](#)
- Ferrule 1.5 (10 pcs) [ECC1-00-0029-H/X](#)
- O-Ring 50.5 x 1.78 mm (10 pcs) [DIC9038/X](#)
- PTFE seal for ECD (33 x 1.6) (3 pcs) [ECC1-01-0043-D/3](#)
- PTFE seal for ECD-3 piston (3 pcs) [ECC1-01-0044-C/3](#)
- Spacer disc (set) 2.1-2.7 [ECC1-01-0374-A](#)
- Spacer disc (set) 2.1-2.3 [ECC1-01-0012-F](#)
- Spacer disc (set) 1.8-2.0 [ECC1-01-0012-G](#)
- Spacer disc (set) 1.5-1.7 [ECC1-01-0012-H](#)
- Spacer disc (set) 1.2-1.4 [ECC1-01-0012-K](#)
- Spacer disc (set) 0.9-1.1 [ECC1-01-0012-L](#)
- Separator (GF/A) 12 x 0.26 mm (10 pcs) [ECC1-01-0012-Q/X](#)
- PE Seal II ECD-3 piston (3 pcs) [ECC1-01-0044-D/3](#)
- O-Ring 2.0 mm x1.0 mm (AP312) (10 pcs) [DIC9037/X](#)

### Sensor Unit:

- Socket screw [DIN-912 M4 x 12](#)

## 18 Spare Parts

### Components Sensor Unit

There are no further spare parts available for the sensor unit. For repair, please contact EL-CELL.

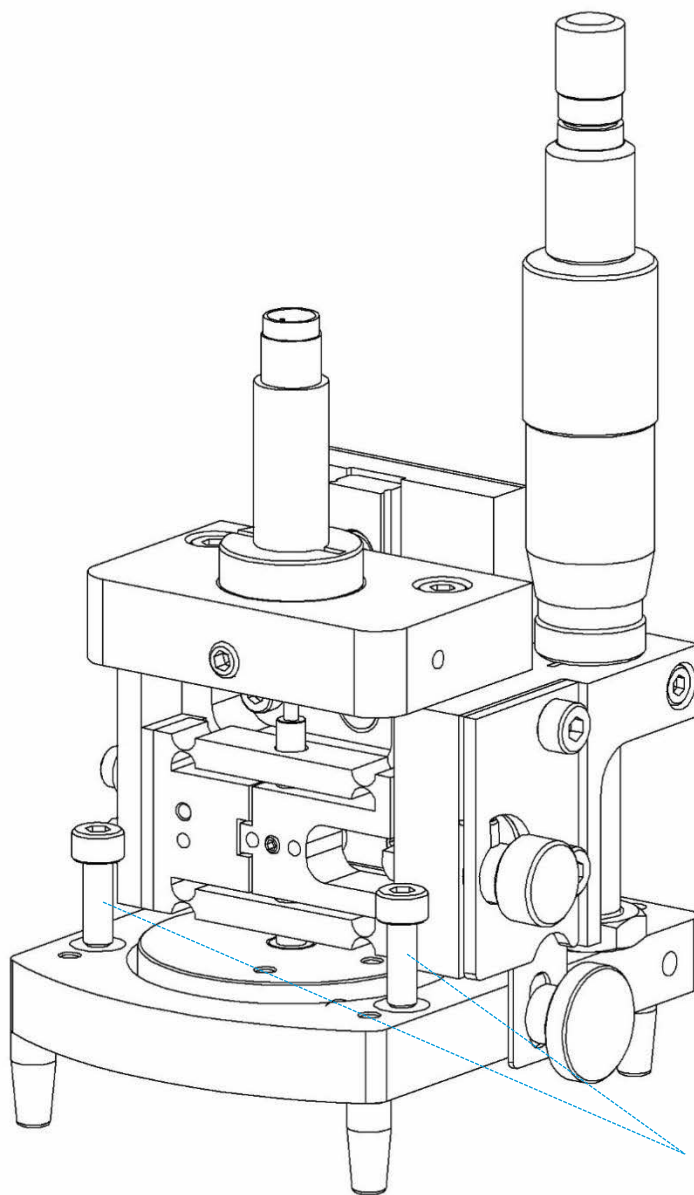
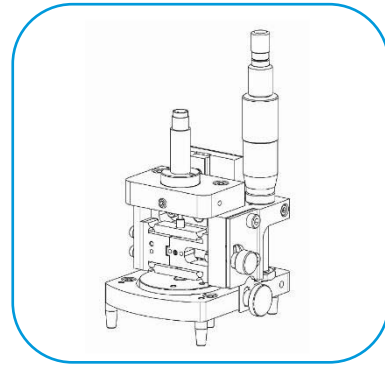

**Socket screw**  
DIN-912 M4x12

# Components Cell Body

## ECD3-00-0002-A

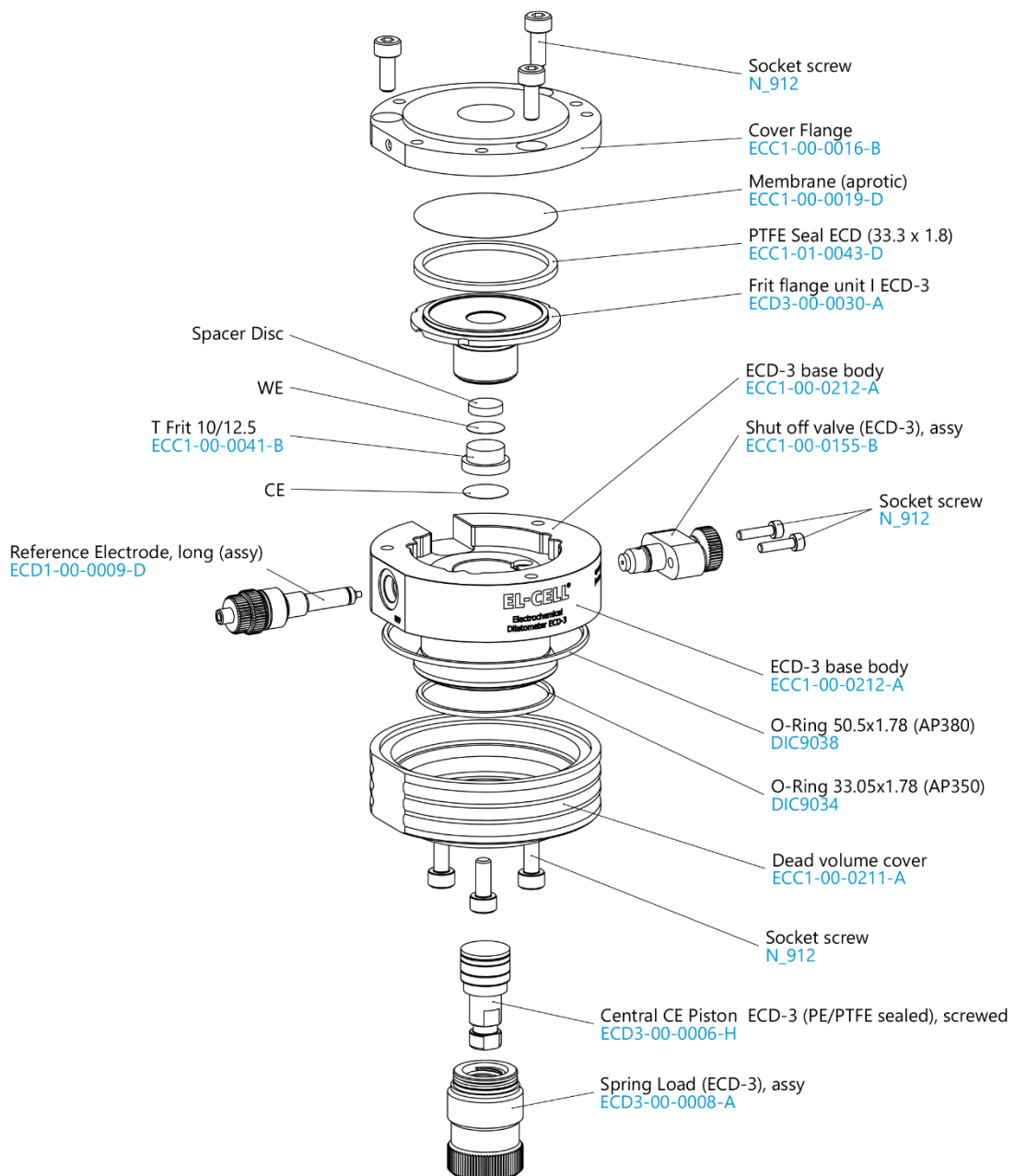
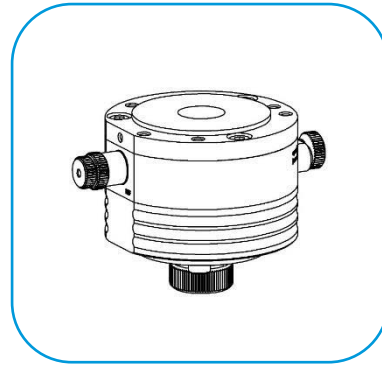

# Shut-off valve (ECD-3), assy

ECC1-00-0155-B

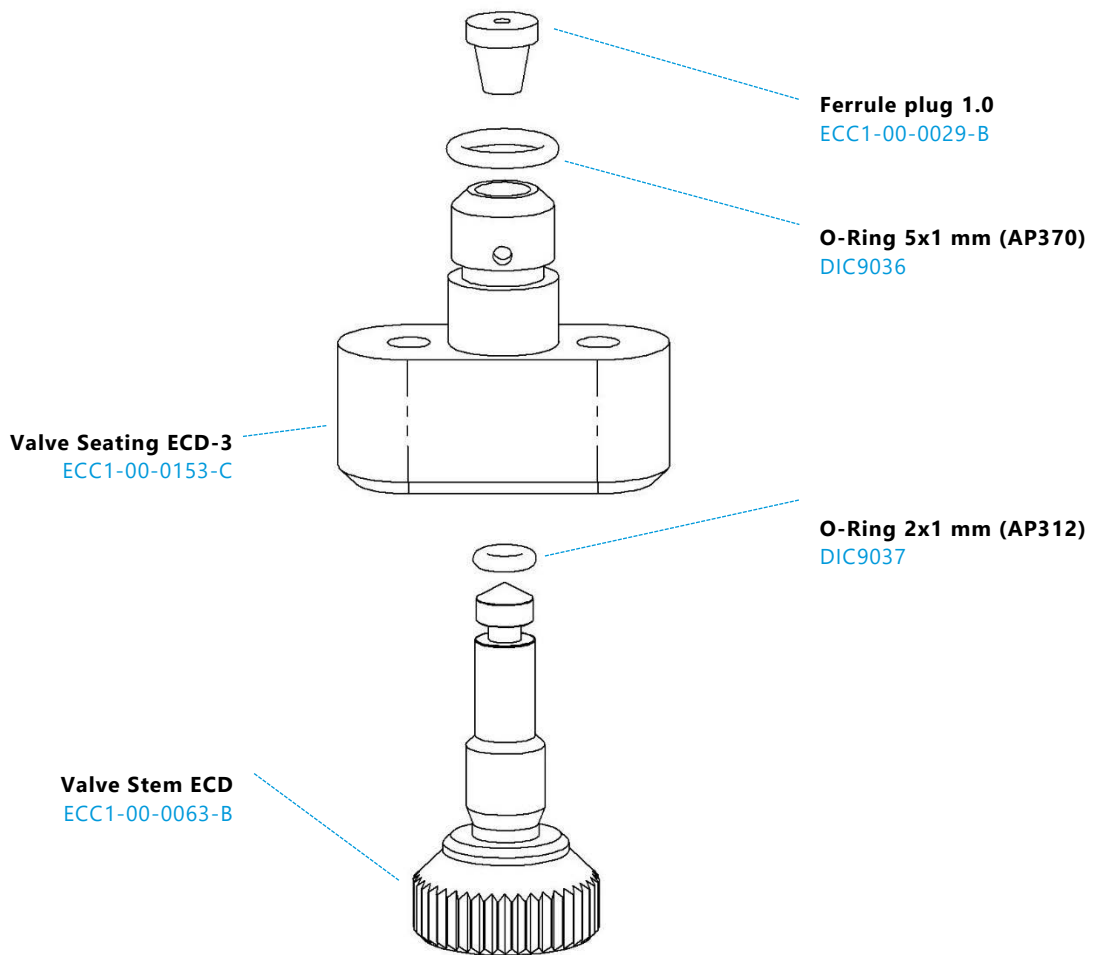
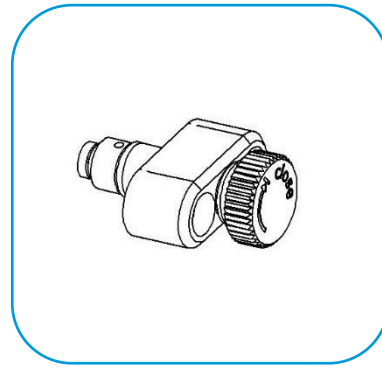



## Central CE piston ECD-3 (PE-sealed), screwed

ECD3-00-0006-D

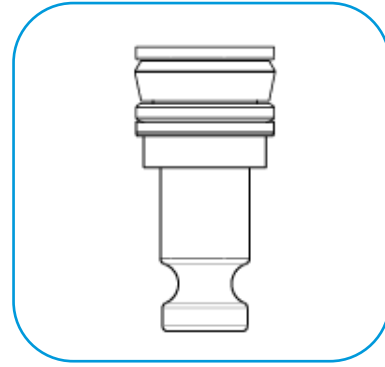

Piston PTFE-sealing, internal thread (ECD-3)  
ECC1-00-0126-O

PTFE Seal ECD-3 piston  
ECC1-01-0044-C

PE Seal II ECD-3 piston  
ECC1-01-0044-D

DIN 7 A 1,5 m6x4 Cylindrical pin (A4)  
NRM0013

Thrust Screw VII (ECD-3)  
ECC1-00-0066-G

Socket screw  
N\_912

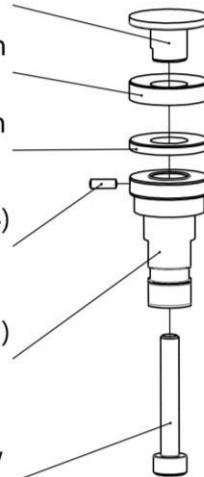

## Spring load (ECD-3), assy

ECD3-00-0008-A

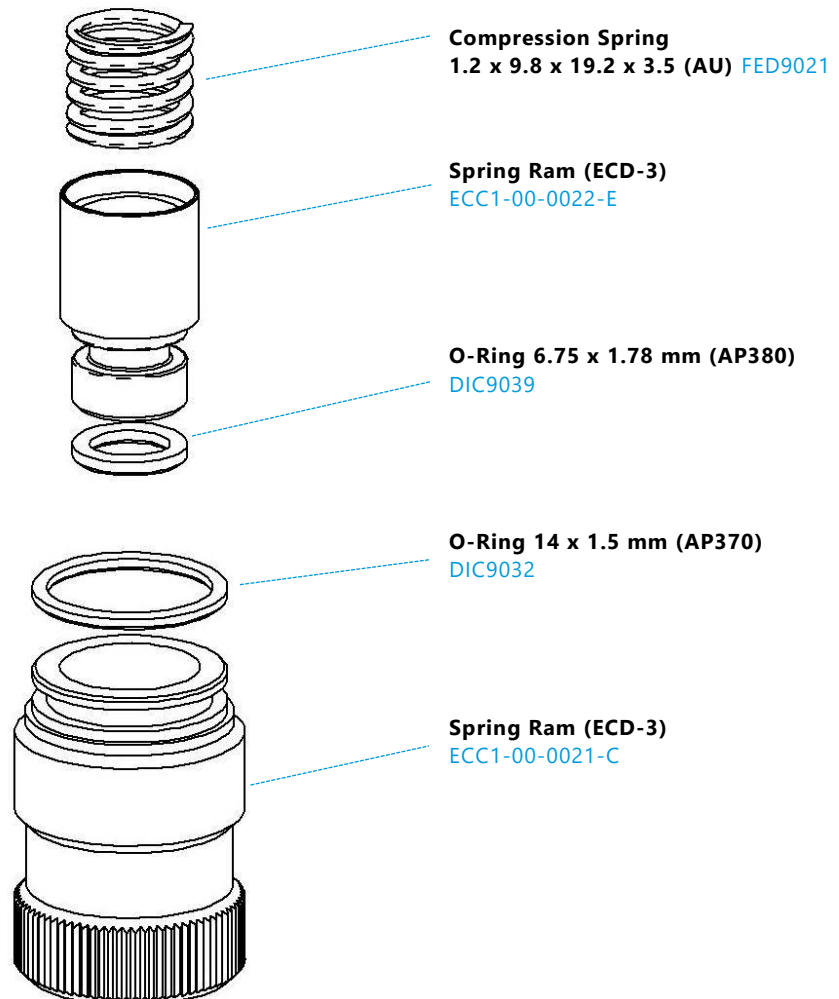
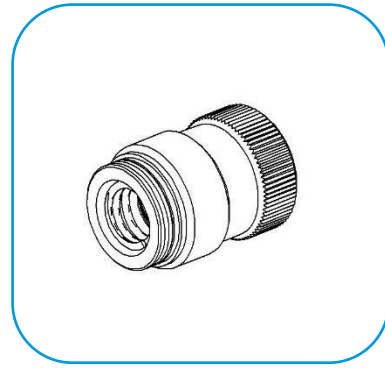

# REF electrode ECD, long, assy (1.4404)

ECD1-00-0009-D

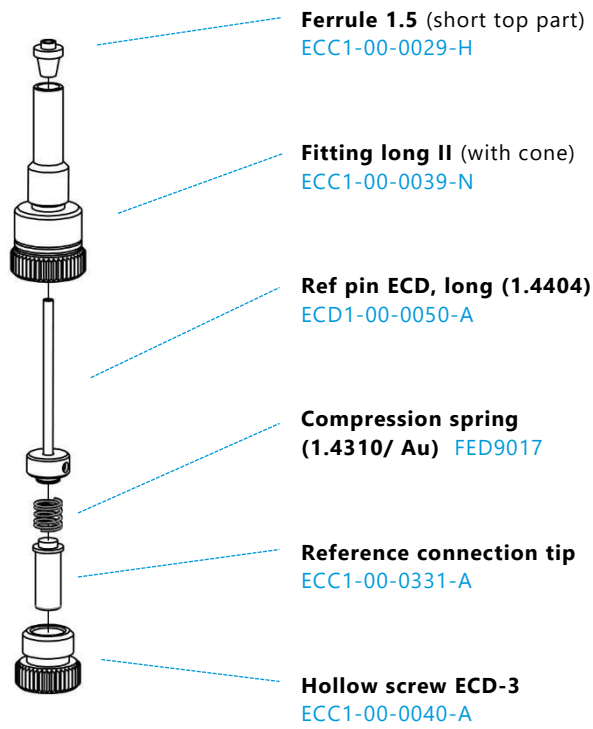
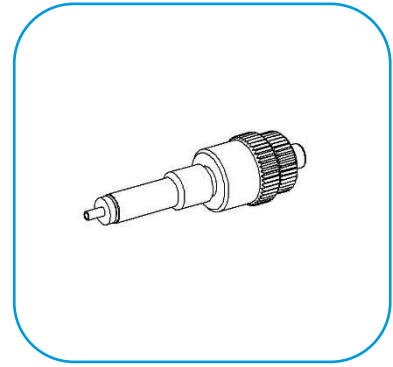

## 19 Connector and Cable Pin-out

### Sensor Cable (5 x 1 x 0.14 mm<sup>2</sup>, shielded):

ECE1-00-0036-A

One end of the cable is terminated by a SUB-D F15 connector (to box); the other end is terminated by a round Binder series 712 connector (to LVDT sensor). The cable shield is tied to both connector housings.

Sub-D F15 Pin #	Series 712 Pin #	Signal	Cable Color
1	1	Secondary +	White
2	2	Secondary -	Brown
3	5	Secondary Mid	Grey
4	-	-	-
5	4	Primary -	Blue
6	3	Primary +	Black

## Cell Cable (4 x 2 x 0.25 mm<sup>2</sup>, TP, shielded):

ECE1-00-0033-F

One end of the cable is terminated by a Sub-D HD M15 connector (to box); 2 mm banana connectors terminate the other end. A Pt100 sensor is located beneath the black shrink tube at the end of the cable pointing to the dilatometer. The cable shield is tied to the Sub-D connector housing.

Pin #	Signal	Cable Color	Color of 2 mm connector
1	V1	Red	Red
2	V2	Blue	Blue
3	-	-	-
4	REF	Grey	Grey
5	I2	Yellow	Yellow
6	-	-	-
7	-	-	-
8	-	-	-
9	-	-	-
10	I2	Green	Green
11	Pt100(1)	Brown	-
12	Pt100(2)	White	-
13	-	-	-
14	-	-	-
15	-	-	-

## Biologic Auxiliary Cable (2 x 2 x 0.14 mm<sup>2</sup>, TP, shielded):

ECE1-00-0039-B

One end of the cable is terminated by a Sub-D HD F15 connector (to the data logger connector at the controller box); the other end is terminated by a Sub-D M9 connector (to the auxiliary input connector of the Biologic potentiostat). The cable shield is tied to both connector housings.

Sub-D HD F15 to box			Sub-D M9 to Biologic AUX Input		
Pin #	Signal	Cable Color	Pin #	Signal	Comments
1					
2					
3					
4					
5					
6					
7					
8					
9					
10	GND	Brown	7	GND	
11					
12					
13	Temperature	Green	6	Analog IN 2	-10..10V; 200°C/V
14					
15	Displacement	White	1	Analog IN 1	-10..+10V; ca. 50 µm/V

## 20 Technical support

EL-Cell GmbH exclusively provides technical support for this product.

### **EL-Cell GmbH**

Tempowerkring 8  
21079 Hamburg - Germany

**phone:** +49 40 79012-737

**fax:** +49 40 79012-736

**e-mail:** [info@el-cell.com](mailto:info@el-cell.com)

**web:** [www.el-cell.com](http://www.el-cell.com)

## 21 Warranty

For a period of one year from the date of shipment, EL-Cell GmbH (hereinafter Seller) warrants the goods to be free from defect in material and workmanship to the original purchaser. During the warranty period, Seller agrees to repair or replace defective and/or nonconforming goods or parts without charge for material or labor, or, at the Seller's option, demand return of the goods and tender repayment of the price. Buyer's exclusive remedy is repair or replacement of defective and nonconforming goods, or, at Seller's option, the repayment of the price.

Seller excludes and disclaims any liability for lost profits, personal injury, interruption of service, or for consequential incidental or special damages arising out of, resulting from, or relating in any manner to these goods.

This Limited Warranty does not cover defects, damage, or nonconformity resulting from abuse, misuse, neglect, lack of reasonable care, modification, or the attachment of improper devices to the goods. This Limited Warranty does not cover expendable items. This warranty is void when repairs are performed by a non-authorized person or service center. At Seller's option, repairs or replacements will be made on site or at the factory. If repairs or replacements are to be made at the factory, Buyer shall return the goods prepaid and bear all the risks of loss until delivered to the factory. If Seller returns the goods, they will be delivered prepaid and Seller will bear all risks of loss until delivery to Buyer. Buyer and Seller agree that this Limited Warranty shall be governed by and construed in accordance with the laws of Germany.

The warranties contained in this agreement are in lieu of all other warranties expressed or implied, including the warranties of merchantability and fitness for a particular purpose.

This Limited Warranty supersedes all prior proposals or representations oral or written and constitutes the entire understanding regarding the warranties made by Seller to Buyer. This Limited Warranty may not be expanded or modified except in writing signed by the parties hereto.