

User Manual

Release 1.93

Electrochemical Test Cell ECC-Air



December 2023

The information in this manual has been carefully checked and believed to be accurate; however, no responsibility is assumed for inaccuracies.

EL-Cell GmbH maintains the right to make changes without further notice to products described in this manual to improve reliability, function, or design. EL-Cell GmbH does not assume any liability arising from the use or application of this product.

EL-Cell GmbH

Tempowerkring 8

21079 Hamburg - Germany

phone: +49 40 79012-734

fax: +49 40 79012-736

e-mail: info@el-cell.com

web: www.el-cell.com

Content

- 1 Product description 4
- 2 Features 5
- 3 Safety precautions 6
- 4 Unpacking 6
- 5 Cell assembly 8
- 6 Operation modes / gas supply10
- 7 Electrical connection11
- 8 Disassembly and cleaning11
- 9 Spare parts12
- 10 Technical support.....14
- 11 Warranty14
- 12 Transfer lines15

1 Product description

The ECC-Air is another member of the modular ECC series. It is dedicated to the electrochemical characterization of gas diffusion electrodes in aprotic electrolytes, in particular for lithium-air batteries.

Basically, the cell accommodates a counter electrode (e.g. Li metal) on the cell bottom, a gas diffusion electrode on top and a separator in between. The upper gas diffusion electrode is contacted by and "breathes" through the perforated plate (current collector) above. The cell lid is equipped with one port for gas inlet and one for gas outlet (Tubes are not included, see page 15), so that the compressed gas can be passed along the backside of the gas diffusion electrode and leave the cell through the siphon. The ECC-Air includes a reference electrode, which is located at the separator's edge.

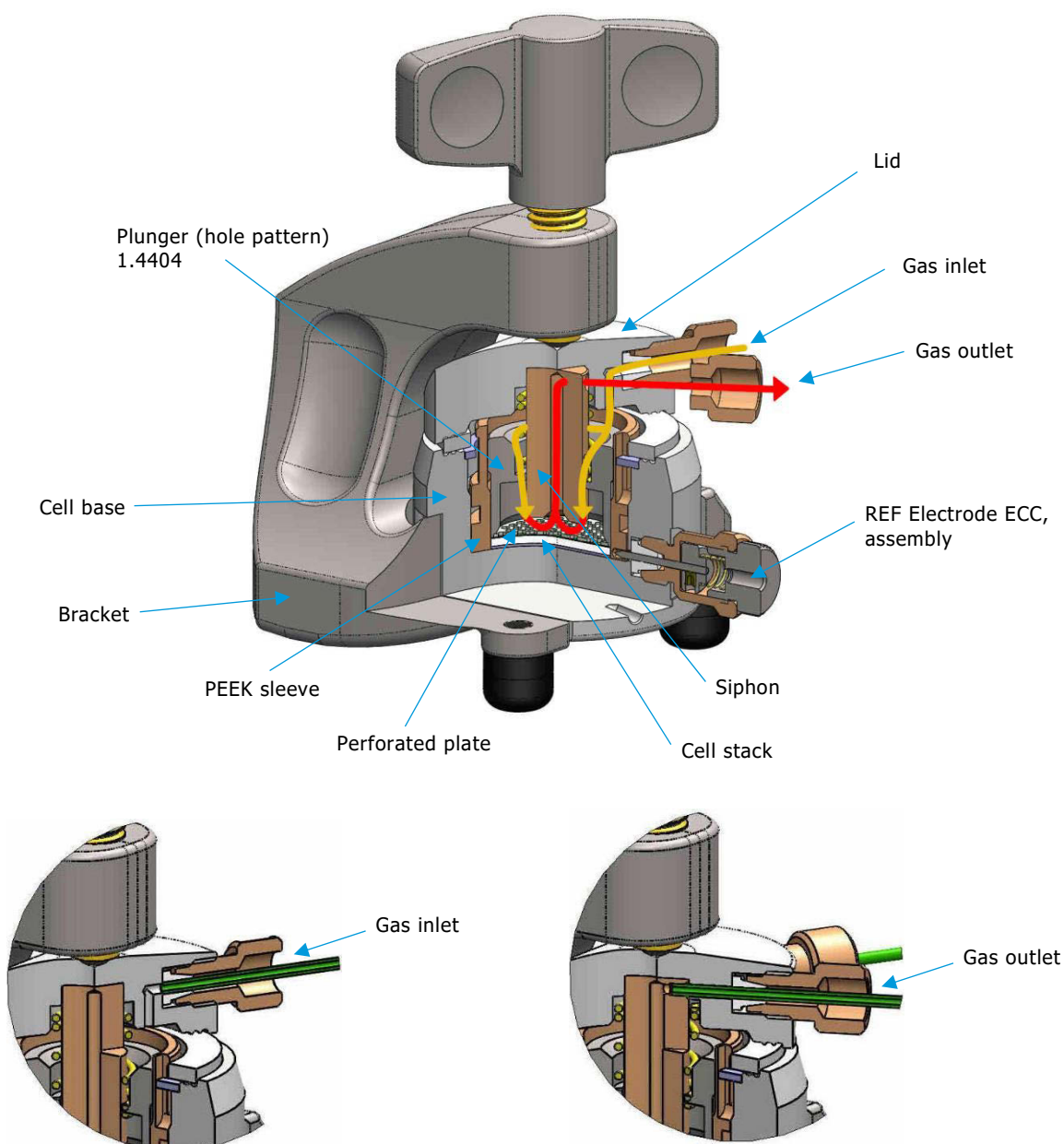

2 Features

- Test cell dedicated to the characterization of gas diffusion electrodes in aprotic media.
- Upper electrode is contacted by and breathes through a perforated plate (current collector)
- Gas inlet and outlet for supply of pressurized gases to the gas diffusion electrode
- A siphon directs the incoming and outgoing gas
- Cell dead volume (head space) of approx. 4.3 cm³
- High precision 18 mm diameter sandwich geometry with <0.1 mm electrode concentricity
- Reliable low leakage sealing with PE seal and PTFE ferrules
- Temperature operation range -20 to +70 °C
- Easy and reliable electrolyte filling upon assembly
- Fast assembly and dismantling and easy cleaning of cell components
- Electrodes are easily accessible for post-mortem analysis
- Reusable cell components except for PE seal
- Small and defined electrolyte volume due to minimized dead volume
- Adjustable, reproducible and homogeneous mechanical pressure on electrodes

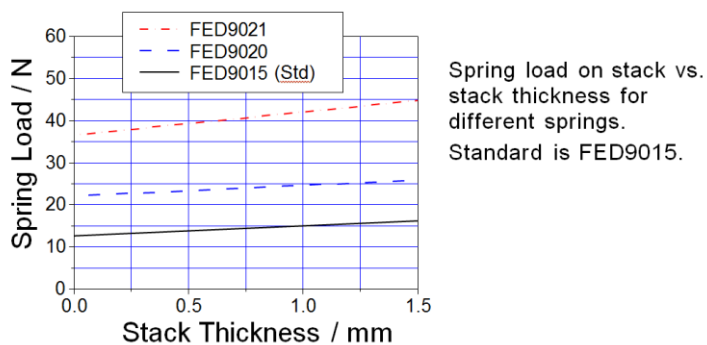

- Materials in media contact are stainless steel 1.4404 (SS 316L) and PEEK. Other materials available on request.
- Modular cell construction with many interchangeable components.
- Size (including bracket): 90 mm x 54 mm x 70 mm (height x width x depth). Weight: 640 g
- Dedicated tools available to ease cell assembly and operation see <http://el-cell.com>

3 Safety precautions

Use proper safety precautions when using hazardous electrode materials and electrolytes. Wear protective glasses and gloves to protect you against electrolyte that may accidentally spill out during disassembly. Upon cell disassembly, dispose all materials properly. Metallic lithium and some insertion compounds may decompose heavily in contact with water and other solvents, and can cause fire.

4 Unpacking

Check the contents of the packages against the list given below to verify that you have received all of the required components. Contact EL-Cell, if anything is missing or damaged.

NOTE: Damaged shipments must remain within the original packaging for freight company inspection.

List of components:

- **ECC-Air test cell**, fully equipped for use with and without reference
- **1** Ref electrode ECC (1.4404) – [ECC1-00-0010-E](#)
- **2** Sleeve (REF) – [ECC1-00-0058-B](#)
- **3** Locking washer – [ECC1-00-0061-A](#)
- **4** Sleeve removing tool – [ECC1-00-0092-A](#)
- **5** PE seal (10 pcs) – [ECC1-00-0053-A/X](#)
- **6** Glass fiber separator 18mm x 1.55mm (10 pcs) – [ECC1-01-0012-C/X](#)

Provided fittings for transfer lines:

- **7** Nut – [ECC1-00-0125-A](#) (2 pcs)
- **8** Ferrule 1.6 (2 Pcs) – [ECC1-00-0029-E](#)



NOTE: Transfer lines are required to run the test cell, but are not included in the shipping. We recommend the use of stainless steel or PEEKsil™ capillary tubing.

5 Cell assembly

In order to operate the test cell with a reference, the small feed-through hole of the REF sleeve is to be loaded with the reference material. Usually metallic lithium. The vertical position of the reference is determined by the thickness of the components. Make sure that the electrodes and separator used, have the appropriate thickness to avoid a short circuit between the reference and anyone of the two other electrodes. The smaller (inside) diameter of the reference bore is 0.3 mm.

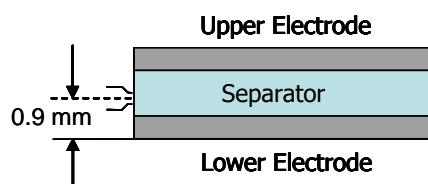

Assembly steps:

1. Prepare the transfer lines for the gas inlet and the gas outlet. The provided fittings are compatible with 1/16 inch outer diameter tubing. We recommend the use of stainless steel or PEEKsil™ capillary tubing (see page XX).
2. Plug the siphon into the cell lid. The side bore at the siphon points to the gas outlet port at the cell lid. Make sure that the siphon is properly attached (see image).

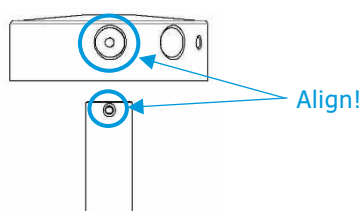

3. Attach the tube to the gas outlet port. The tube end fits into the side bore of the siphon and thus holds the siphon in place
4. Pick up a small piece of lithium by a metal wire. Press the lithium into the feed-through hole of the REF sleeve until the lithium just arrives at the inner face of the sleeve. Note that significant force has to be applied to achieve that. For this purpose, a special REF loading tool is available (not included).
5. Close the side opening of the cell base with the provided PTFE plug. This plug is later on replaced by the reference electrode.
6. Put the perforated plate onto the Plunger.

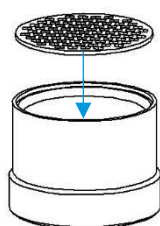

7. Insert the Plunger into the sleeve with the perforated plate pointing upwards.

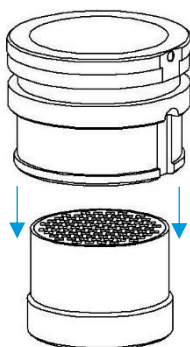

8. Put the 18 mm diameter gas diffusion working-electrode onto the perforated plate inside the sleeve.
9. Put the glass fiber separator onto the working-electrode and dispense a defined amount of electrolyte on it. The optimum amount of electrolyte depends on the electrodes and separator used. It has to be carefully determined in pre-tests. 0.5 cm³ are a reasonable amount for 1.5 mm thick glass fiber separator.
10. Put the lithium CE disc (18 mm diameter, approx. 0.2 mm thick) on top of the cell stack.
11. Put the cell base over the assembly. Hold the components tightly together and turn the assembly back into the upright position.
12. Release the pressure applied on the cell stack. Mount the locking ring in order to align the side opening of the cell base with the feed-through hole of the REF sleeve.
13. Replace the PTFE plug in the Cell base by the REF-Electrode
14. Insert the PE seal and the spring.
15. Place the cell lid with the already attached siphon and transfer lines onto the cell base.
16. Put the cell into the bracket and tighten the wing nut.
17. Connect the inlet port to the gas supply and the outlet tube to the exhaust line.

6 Operation modes / gas supply

Thanks to its modular design, the ECC-AIR test cell may be operated in different modes. Two basic set-ups are described below.

A. Flow-through set-up

This is the most typical configuration for the characterization of Li-air batteries. In the simplest set-up of this kind, the gas inlet is connected to the gas (oxygen) supply via a mass flow controller. The pressure build-up inside the cell is controlled by means of a metering valve (or narrow capillary) connected to the gas outlet.

For gas analysis, the gas outlet may be connected to the "continuous" gas flow inlet of a mass spectrometer.

However, due to the cells considerable dead volume and backmixing the time-resolution of gas analysis is limited. Much better time resolution can be achieved with the [ECC-DEMS](#) test cell.

B. Dead-end pressurized set-up

In this configuration, the gas outlet is plugged. The test cell is pressurized at the beginning of the experiment by means of an external gas supply connected to the gas inlet.

After equilibration of the closed cell at constant temperature (the time constant being mainly determined by the slow dissolution of gases in the electrolyte), the cell is charged/ discharged and the resulting pressure change recorded.

A [gas sample port \(valve\)](#) (P/N [ECC1-00-0155-A](#)) is available as an option. The gas sample port may be used to draw gas samples for subsequent analysis, or to pressurize the cell at the beginning of the experiment by means of a syringe.

7 Electrical connection

The electrical connection of the test cell to the potentiostat or battery tester is depicted below for 3-electrode operation (i.e. using a reference electrode). For 2-electrode operation the RE lead is to be connected to the cell base. Note that some potentiostats may not have the CE sense lead.

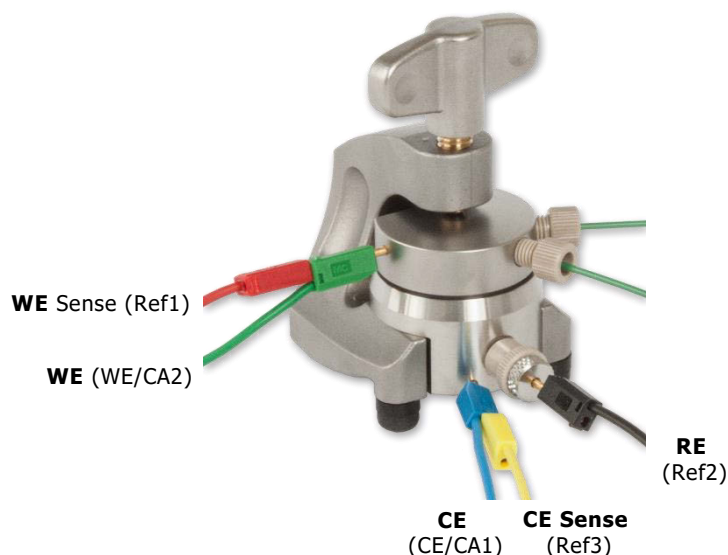

The notations in brackets refer to the standard connection with a Biologic potentiostat (MPG-2, SP, VSP and VMP series).

<http://www.bio-logic.info/electrochemistry-ec-lab/instruments/>

8 Disassembly and cleaning

Right after use, disassemble the cell in the reverse order of assembly. All chemicals used have to be disposed properly. Clean wetted parts with water and/or other appropriate solvent. Ultrasonic cleaning is recommended. Persistent dirt on the cell base and plunger may be removed by treatment with aqueous nitric acid (20%, 2 hours at room temperature). After cleaning, all parts are to be dried at 80°C in vacuum overnight. PE seal and PTFE ferrules are to be replaced.

NOTE: Leaving cell parts in contact with ambient atmosphere while still being wetted with electrolyte may result in severe corrosion.

9 Spare parts

ECC-Air test cell

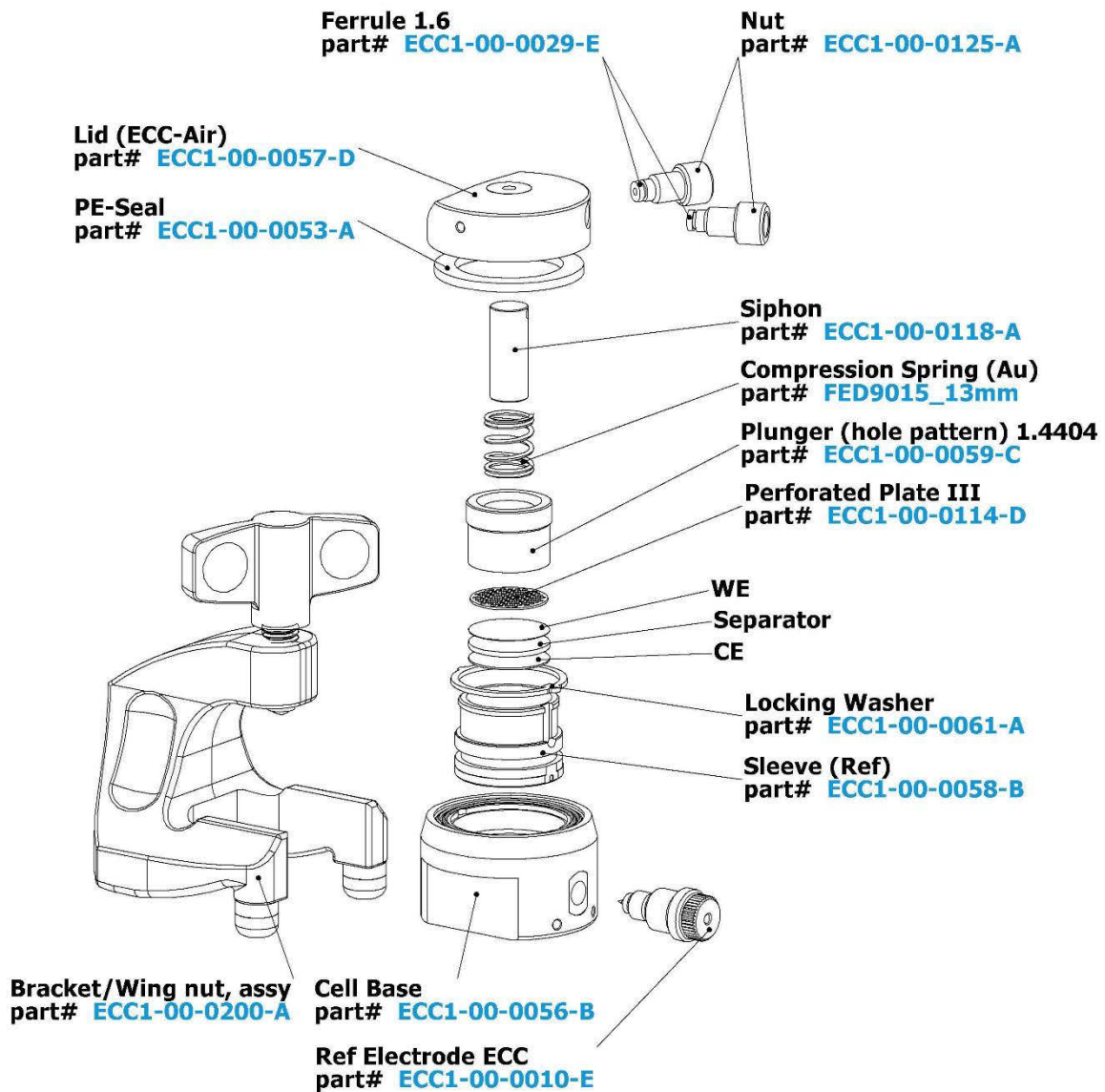
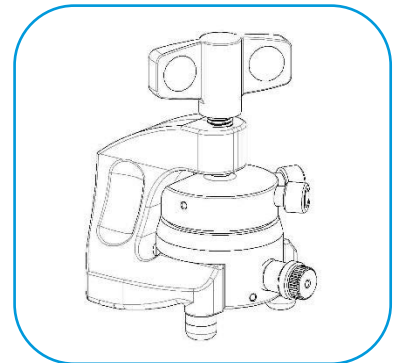

Ref electrode ECC (1.4404)
ECC1-00-0010-E

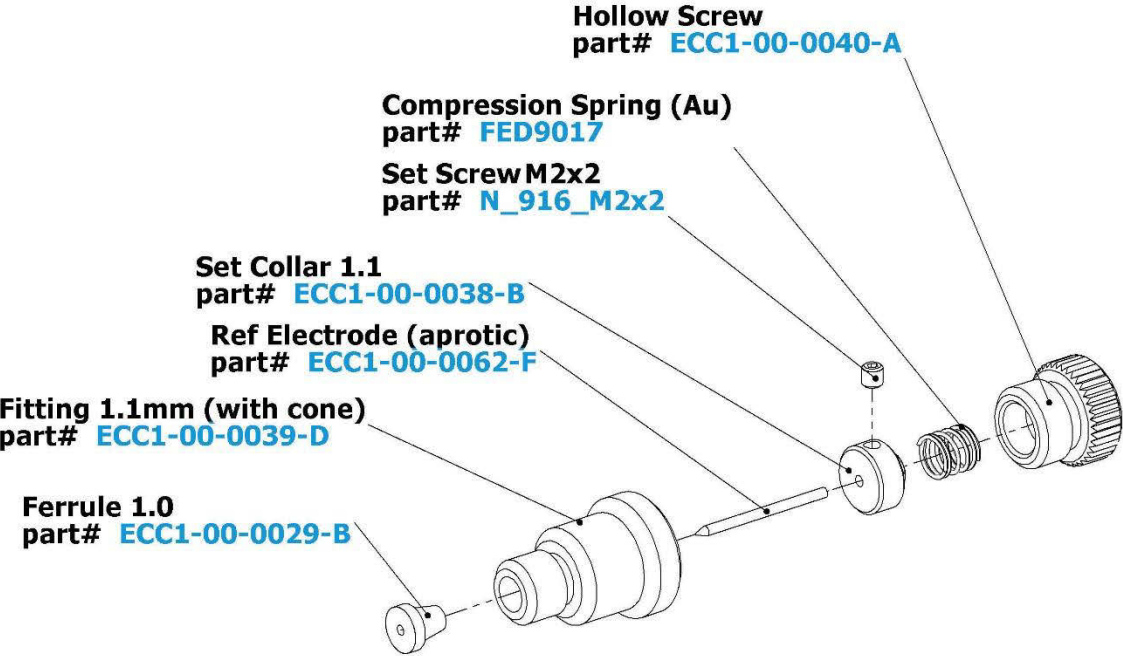
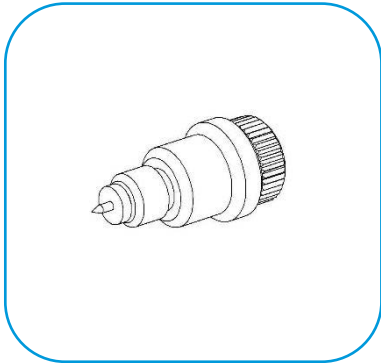

10 Technical support

Technical support for this product is exclusively provided by EL-Cell GmbH.

Please be sure to contact our customer service department before making a return. We will not open or process shipments without a completed decontamination report or RMA.

EL-Cell GmbH

Tempowerkring 8
21079 Hamburg - Germany

phone: +49 40 79012-734

fax: +49 40 79012-736

e-mail: support@el-cell.com

web: www.el-cell.com

11 Warranty

For a period of one year from the date of shipment, EL-CELL GmbH (hereinafter Seller) warrants the goods to be free from defect in material and workmanship to the original purchaser. During the warranty period, Seller agrees to repair or replace defective and/or nonconforming goods or parts without charge for material or labor, or, at the Seller's option, demand return of the goods and tender repayment of the price. Buyer's exclusive remedy is repair or replacement of defective and nonconforming goods, or, at Seller's option, the repayment of the price.

Seller excludes and disclaims any liability for lost profits, personal injury, interruption of service, or for consequential incidental or special damages arising out of, resulting from, or relating in any manner to these goods.

This Limited Warranty does not cover defects, damage, or nonconformity resulting from abuse, misuse, neglect, lack of reasonable care, modification, or the attachment of improper devices to the goods. This Limited Warranty does not cover expendable items. This warranty is void when repairs are performed by a non-authorized person or service center. At Seller's option, repairs or replacements will be made on site or at the factory. If repairs or replacements are to be made at the factory, Buyer shall return the goods prepaid and bear all the risks of loss until delivered to the factory. If Seller returns the goods, they will be delivered prepaid and Seller will bear all risks of loss until delivery to Buyer. Buyer and Seller agree that this Limited Warranty shall be governed by and construed in accordance with the laws of Germany.

The warranties contained in this agreement are in lieu of all other warranties expressed or implied, including the warranties of merchantability and fitness for a particular purpose.

This Limited Warranty supersedes all prior proposals or representations oral or written and constitutes the entire understanding regarding the warranties made by Seller to Buyer. This Limited Warranty may not be expanded or modified except in writing signed by the parties hereto.

12 Transfer lines

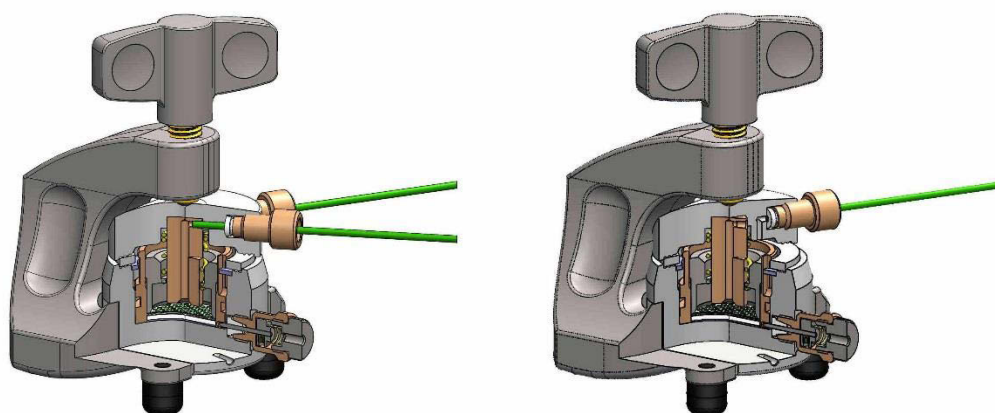

Assembly:

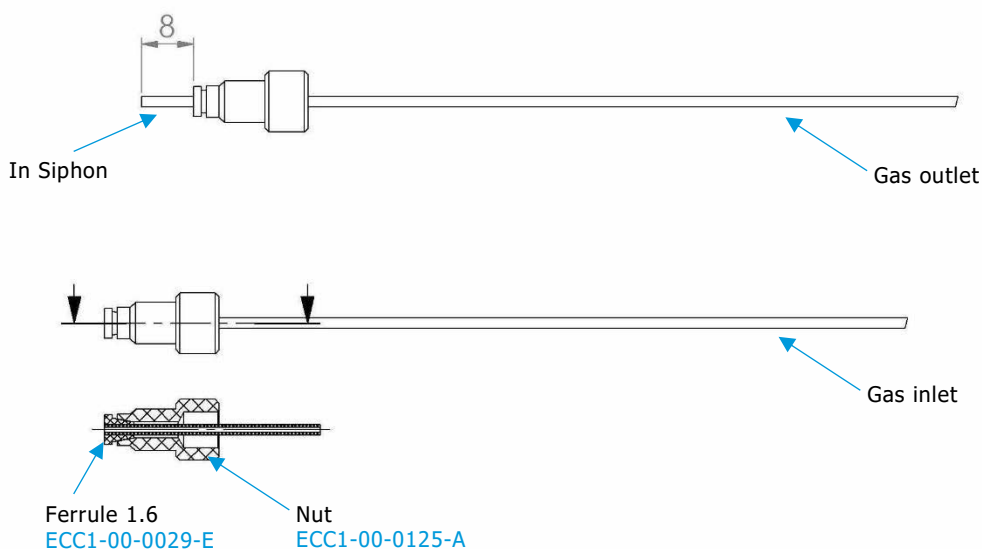

The provided fittings are compatible with 1/16 inch outer diameter tubing. We recommend the use of stainless steel or PEEKsil™ capillary tubing

NOTE: When using metal tubes, there could be a grounding of the cell lid and the upper electrode. The grounding could cause problems with the potentiostat. Consider to use a floating mode potentiostat when metal tubes are used.