

User Manual

Release 1.3

PAT-Cell-Opto-10

Electrochemical test cell



Disclaimer

EL-Cell GmbH makes no assurances or warranties with respect to this manual and, to the extent permitted by law, limits its liability for violation of any implied warranty to the substitution of this manual for another. In addition, EL-Cell GmbH reserves the right to revise this publication at any time without notice to anyone.

The information provided in this documentation includes general descriptions and/or technical characteristics regarding the performance of the equipment described herein. This documentation cannot serve as a proper evaluation of the suitability or reliability of the equipment for any specific application by any user and should not be relied upon as a substitute for such evaluation. It is the responsibility of each such user or installer to conduct an appropriate and complete risk assessment, evaluation and testing of the equipment with respect to their specific application. EL-Cell GmbH cannot be held responsible or liable for any misuse of the information contained herein.

All relevant state, regional and local safety regulations must always be complied with when installing and using this device. For safety reasons and to ensure compliance with the documented system data, only the manufacturer is authorized to perform repairs on components.

Disregarding this information may result in injury or damage to the equipment.

All rights reserved. No part of this publication may be reproduced, processed, or transmitted in any form, including photocopying, recording, or any other electronic or mechanical process, without the written permission of the publisher. Requests for permission must be made in writing to the publisher at the address written below.

Manufacturer and customer service

EL-Cell GmbH
Tempowerkring 8
21079 Hamburg – Germany

Telephone: +49 40 79012-734
Telefax: +49 40 79012-736
Email: info@el-cell.com
Website: el-cell.com

Technical support

Telephone: +49 40 79012-734
Email: support@el-cell.com
Website: el-cell.com/support/technical-support/

Please always quote the serial number on the nameplate when making customer service inquiries.

Shipping address for repairs

EL-Cell GmbH
Tempowerkring 8
21079 Hamburg - Germany

Please be sure to contact our customer service department before making a return. We will not open or process shipments without a completed decontamination report or RMA.

Content

1	Preamble	5
1.1	Purpose and target audience.....	5
1.2	Storage instructions.....	5
1.3	Obtaining documents and information.....	6
2	Product Description	7
2.1	Features	7
2.2	Working principle of the PAT-Cell-Opto-10 (side-by-side setup of electrodes):.....	8
3	Technical data	9
4	Intended use	9
5	Safety Precautions	9
6	Assembly	10
6.1	Lid assembly:	11
6.2	Assembling the cell with a side-by-side sample holder:.....	12
6.3	Assembling the cell with a face-to-face sample holder:	15
7	Connecting the test cell	19
8	Disassembly and Cleaning	19
9	Unpacking	20
10	Components	21
10.1	PAT-Cell-Opto-10.....	21
10.2	Lid unit (OPTO-10) 18 mm	22
11	Warranty	23

1 Preamble

1.1 Purpose and target audience

This manual covers the structure, function, operation and maintenance of the device described. It is intended for the end users of the device. An end user can be described as any person who interacts directly with the device. The term "end user" usually includes laboratory personnel who have been specifically trained to operate this instrument and are familiar with all the precautions required to work in the laboratory.

Only an authorized and properly qualified and experienced person 18 years of age or older may use the device described, who:

- has read and understood these installation and operating instructions
- is familiar with the installation and operation of this or a similar device
- is aware of all possible dangers and acts accordingly

1.2 Storage instructions

Make sure you have read and understood the complete instructions and all safety information before using this product. Failure to follow these instructions may result in minor or serious injury.

Follow all instructions. This will prevent accidents that could result in property damage or injury. Keep all safety information and instructions for future reference and pass them on to subsequent users of the product.

The manufacturer is not liable for property damage or injuries resulting from incorrect handling or failure to comply with the safety instructions. In such cases, the warranty becomes void.

1.3 Obtaining documents and information

A current version of the documentation is available on the following website:

<https://el-cell.com/support/manuals/>

Alternatively, you can scan this QR code,
to access the website:



2 Product Description



The PATCell-Opto-10 test cell is designed for operando characterization of electrodes using optical methods such as light microscopy or Raman spectroscopy in reflection mode.

The test cell utilizes the cableless PAT socket for cell connection. This way, it can be directly plugged into a PAT battery tester like the PAT-Tester-x-8 or a PAT docking station to connect it to a third-party battery tester.

2.1 Features

- 2- and 3-electrode cell with optical window for aprotic and aqueous electrochemistry.
- High cycling stability due to glass-to-metal seals
- Suited for light microscopy and Raman spectroscopy
- Cableless cell connection via PAT socket

2.2 Working principle of the PAT-Cell-Opto-10 (side-by-side setup of electrodes):

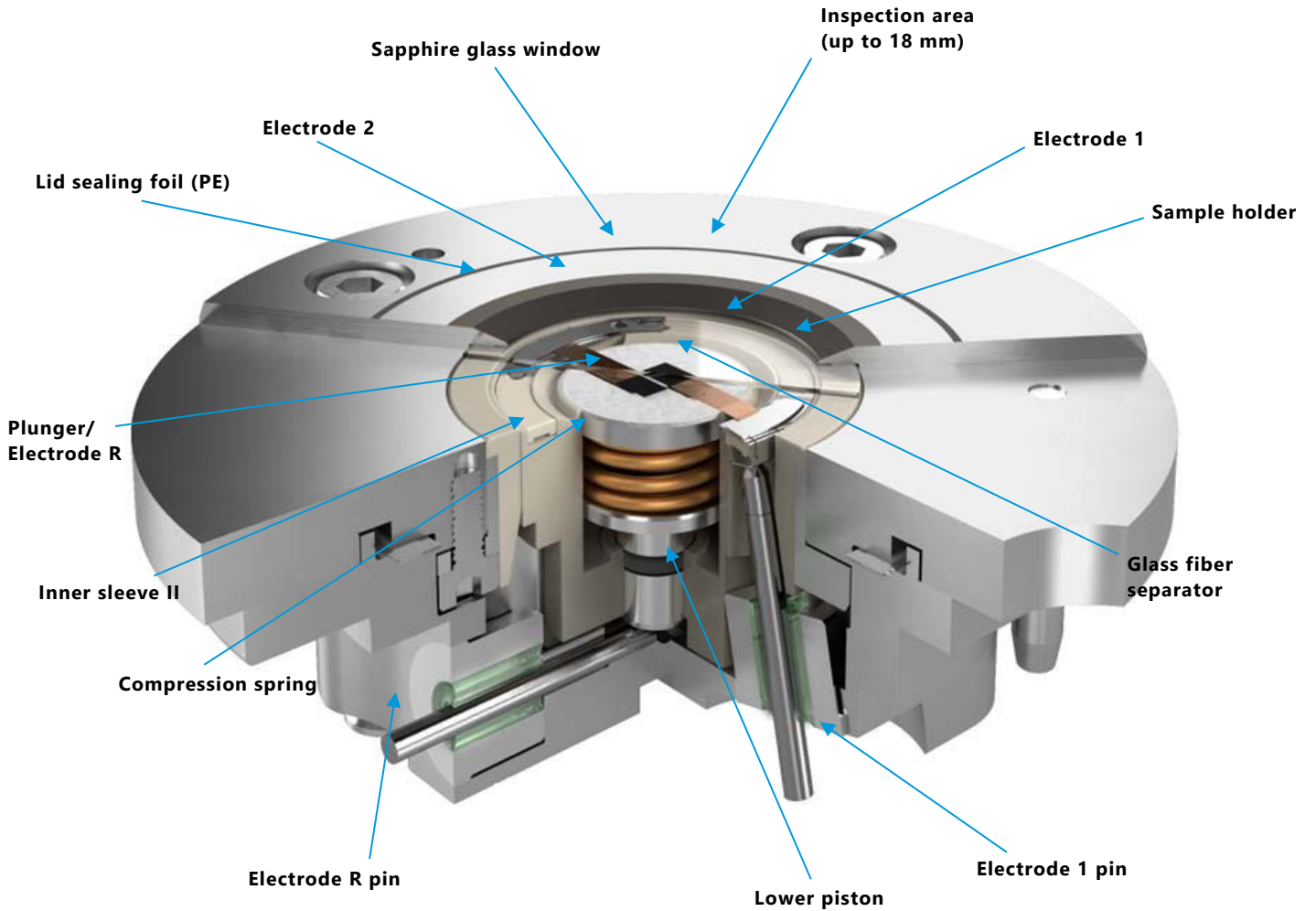

3 Technical data

- Length: 55 mm
- Width: 55 mm
- Height: 32.5 mm
- Weight: 0.3 kg
- Operational temperature: -20° to $+70^{\circ}\text{C}$
- Electrode R diameter: ≤ 10 mm
- Dead volume: 1.8 cm^3

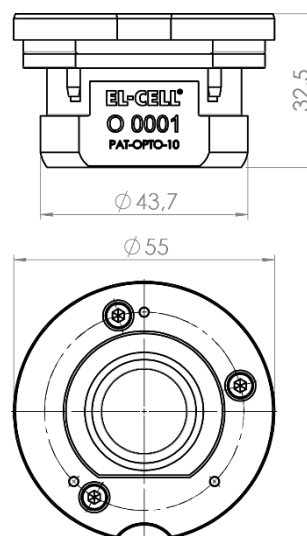

4 Intended use

The PAT-Cell-Opto-10 test cell is an electrochemical measuring instrument designed for use in a laboratory environment. It may only be used by trained personnel and only as described in this manual.

5 Safety Precautions

Use proper safety precautions when using hazardous electrode materials and electrolytes. Wear protective glasses and gloves to protect you against electrolytes that may accidentally spill out during filling and disassembly. Upon cell disassembly, dispose of all materials properly. Metallic lithium and some insertion compounds may decompose heavily in contact with water and other solvents and can cause a fire.

6 Assembly

Please note: All assembly steps are to be carried out in an inert glove box atmosphere. All components used are to be dried upfront in a vacuum oven at 80°C (120°C for parts made of PPS) for at least 12 hours.

Once fully assembled, the cell is hermetically sealed so that it may be operated in an ambient atmosphere.

The test cell can be used in several different configurations, which mainly differ in the type and size of the working electrode used, the charging geometry (the position of the working and counter electrode relative to each other), and the connection to the potentiostat (2- or 3-electrode connection). In the following, the cell assembly is described in several parts.

6.1. Lid assembly

6.2. Instructions for assembling the cell for the **side-by-side** arrangement of electrodes.

6.3. Instructions for assembling the cell for the **face-to-face** arrangement of electrodes.

These instructions can also be viewed as videos on our website el-cell.com.

6.1 Lid assembly:



1. Turn the lid upside down.
Insert the foil sealing into the lid.

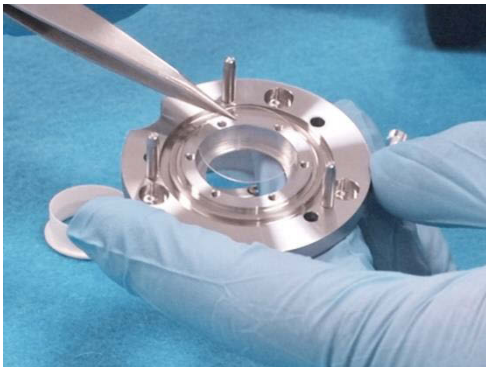

2. Insert the window.

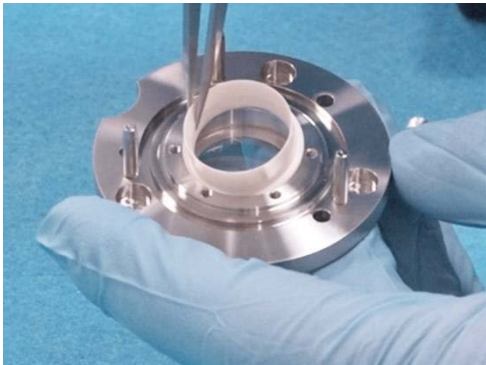

3. Insert the window thrust ring.

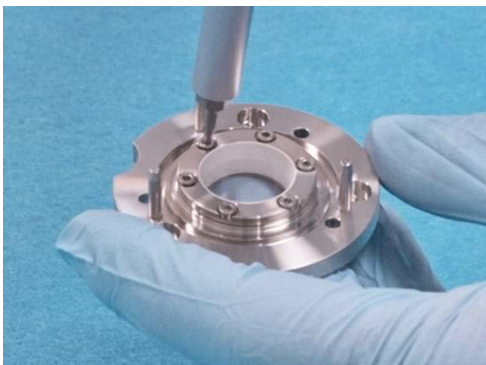

4. Attach the window flange and screw in the screws using the torque screwdriver 0.2 Nm.

6.2 Assembling the cell with a side-by-side sample holder:

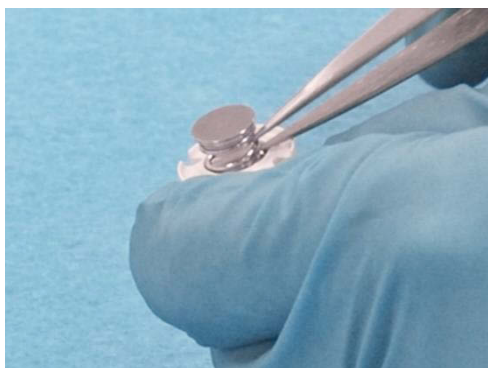

1. Assemble the lid as described above. Then insert the lower piston into the inner sleeve.

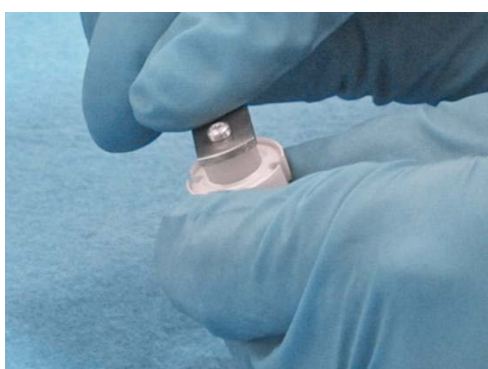

2. Use the loading tweezers to push the piston into the sleeve.

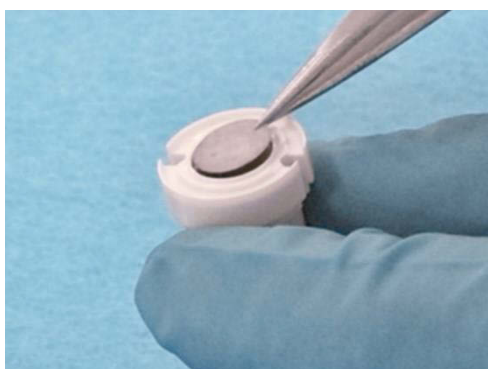

3. Put the electrode R, lithium metal in this case, on top of the piston.

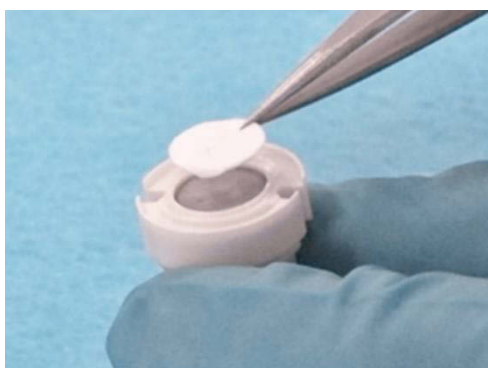

4. Put the separator on top. The separator must not be more than 10 mm in diameter. A smaller separator may be useful to prevent the sample holder from coming into contact with the electrolyte.

Use the loading tweezers again to press the cell stack further into the piston.

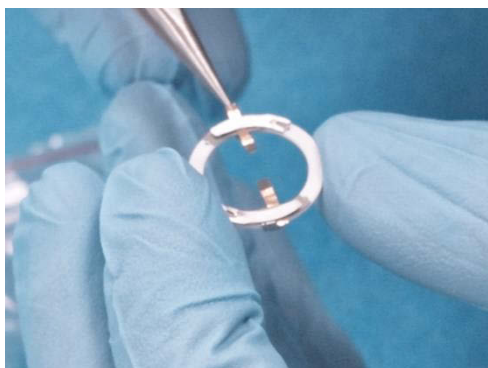

5. Attach the electrode strips to the sample holder.

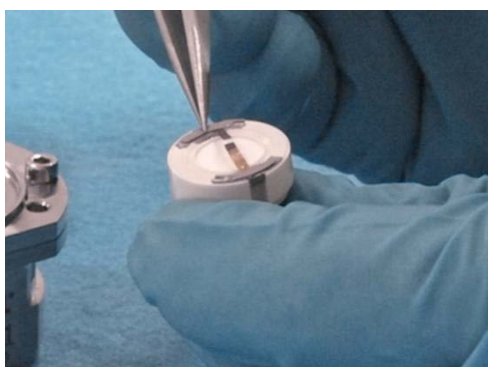

6. Attach the sample holder to the piston assembly.



7. Insert the assembly into the cell base.



8. Drop the electrolyte onto the separator/electrodes. Use only the amount of electrolyte necessary to impregnate the porous material. Avoid excess electrolytes. Typically, less than 50 μ l of electrolyte is suitable.

Note that electrolyte will be squeezed out of the separator when the cell lid is attached.

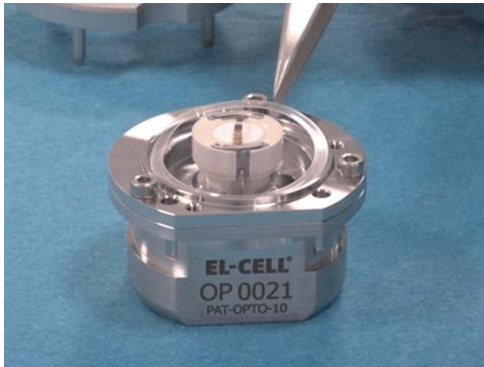

9. Insert the second foil seal.



10. Ensure the electrode strips are correctly aligned before attaching the lid. Then put on the cell lid. Make sure that the flat side of the cell base and the straight line on the lid are parallel.



11. Double-check the proper alignment of the electrode strips.

Then press down the lid and tighten the three screws firmly with the 2.5 mm hexagon screwdriver.



12. The PAT-Cell-Opto-10 is now ready for testing.

6.3 Assembling the cell with a face-to-face sample holder:

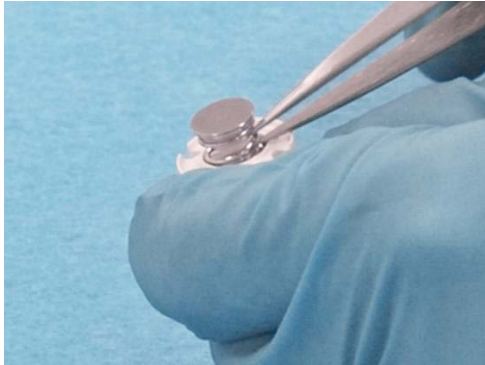

1. Follow the lid assembly steps. Then insert the lower piston into the inner sleeve.

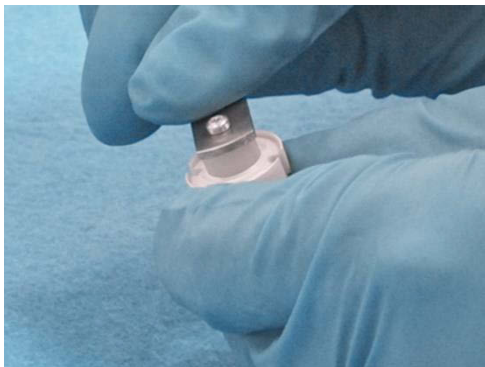

2. Use the loading tweezers to push the piston into the sleeve.

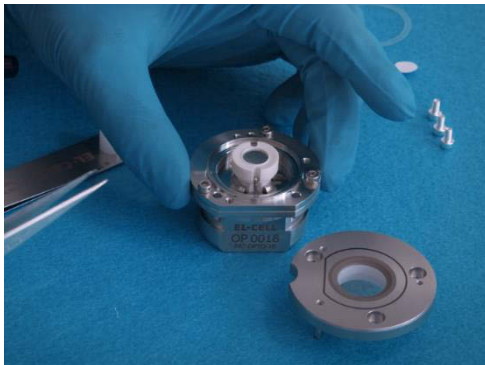

3. Place the assembly into the cell base.



4. Put the self-standing electrode on top.



5. Put the separator on top. The separator must not be more than 10 mm in diameter. A smaller separator may be useful to prevent the sample holder from coming into contact with the electrolyte.



6. Use the loading tweezers again to push the cell stack further down.

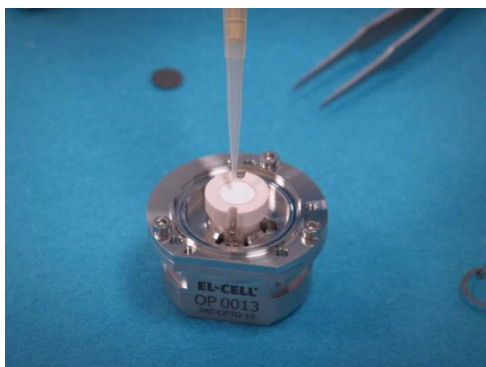

7. Drop the electrolyte onto the separator. Use only the amount of electrolyte necessary to impregnate the porous material. Avoid excess electrolytes. Typically, less than 50 μ l of electrolyte is suitable.

Note that electrolyte will be squeezed out of the separator when the cell lid is attached.



8. Put the self-standing electrode on top.



9. Push down the electrode stack using the loading tweezers.



10. Insert the contact ring.



11. Put the holed current collector on top. Choose the hole size depending on the magnification used by the microscope.



12. Insert the second foil seal.

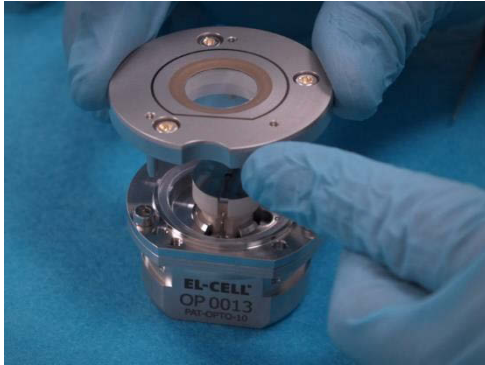

13. Put on the cell lid. Make sure that the flat side of the cell base and the straight line on the lid are parallel.

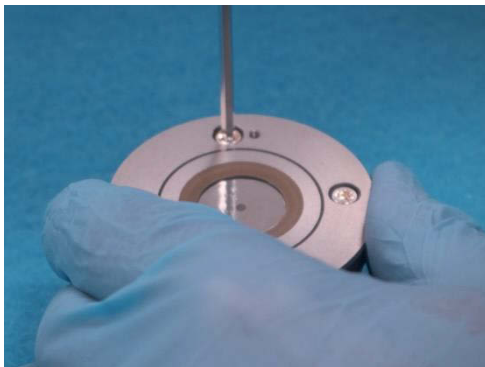

14. Finally, screw the cover on with the 2.5 mm hexagon screwdriver.

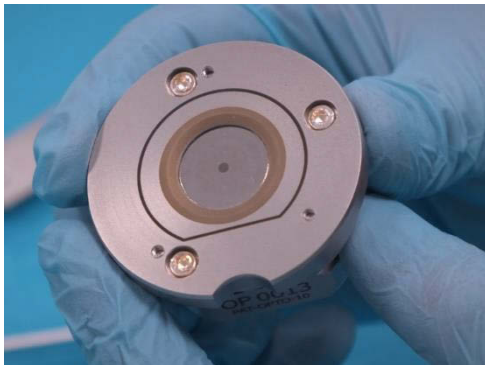

15. The PAT-Cell-Opto-10 is now ready for testing.

7 Connecting the test cell

The PAT-Cell-Opto-10 is connected via the cableless PAT socket. It can be directly plugged into any EL-Cell PAT-Tester or PAT docking station.

8 Disassembly and Cleaning

When working with aprotic, moisture-sensitive electrolytes such as LiPF_6 , it is best to always leave the cell base and cell lid in the glove box. Cell components should only be exposed to room air for cleaning or disposal.

Right after use, disassemble the cell in the reverse order of assembly. All chemicals used have to be disposed of properly. All wetted parts must be cleaned with water and/or other appropriate solvents. All parts are to be dried immediately after cleaning at 80°C . All cell parts made of PPS are to be dried immediately after cleaning overnight at 120°C .

If the cell base is contaminated with electrolyte, clean it in the glove box with a cloth and a battery-compatible solvent such as DMC.

Never immerse the cell base in liquid. In particular, avoid contact of the electronic components on the bottom of the cell base with liquid.

Please note:

- Protect yourself against chemical hazards. Electrolytes may spill out during cleaning. Electrode materials and electrolytes may react with ambient atmosphere or solvents used for cleaning. Wear appropriate protective equipment, goggles, and gloves.
- Clean all cell parts right after disassembly. Leaving cell parts in contact with the ambient atmosphere while still being wetted with electrolyte may result in severe corrosion.

9 Unpacking

Check the contents of the packages against the list given below to verify that you have received all of the components. Contact the factory if anything is missing or damaged.

NOTE: Damaged shipments must remain with the original packaging for freight company inspection.

List of Components:

1. **PAT-Cell-Opto-10** test cell with flat socket, fully equipped for use in both 2-electrode and 3-electrode (reference) configuration
2. **Windows seal (10 pcs.)** [ECC1-05-0016-B/X](#)
3. **Separator 10.0 mm x 0.26 mm, GF/A (10 pcs.)** [ECC1-01-0012-R/X](#)
4. **PE Sealing foil (10 pcs.)** [ECC1-05-0032-A/X](#)
5. **Loading tweezer** [ECC1-09-2010-B](#)
6. **Torque screwdriver, 0.2 Nm, cross handle** [WZG9021](#)
7. **Inbus bit 1.5 mm x ¼ inch** [WZG9046](#)
8. **Hexagon screwdriver 2.5 mm, cross handle** [WZG9047](#)
9. **Sample holder (side-by-side)** [ECC1-05-0040-B](#)
10. **Contact ring (face-to-face)** [ECC1-05-0039-C](#)
11. **Contact disc (50 fold)** [ECC1-05-0042-C](#)
12. **Contact disc (100 fold)** [ECC1-05-0042-A](#)
13. **Contact disc (200 fold)** [ECC1-05-0042-B](#)

10 Components

10.1 PAT-Cell-Opto-10

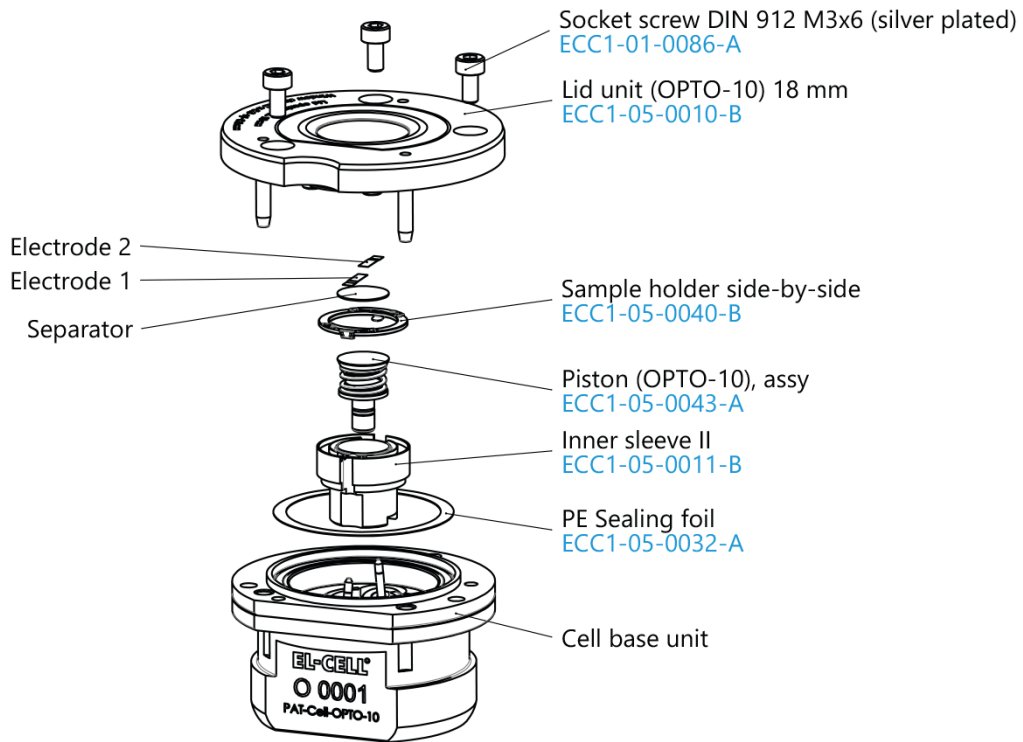
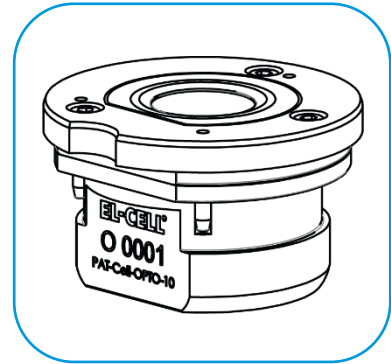

10.2 Lid unit (OPTO-10) 18 mm

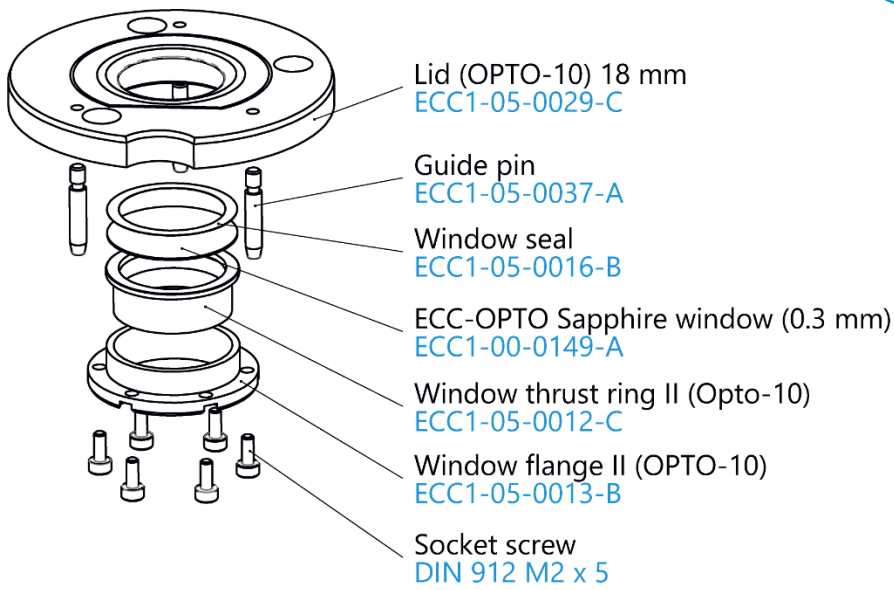
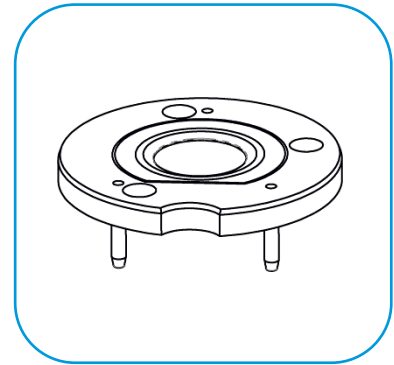

11 Warranty

For a period of one year from the date of shipment, EL-Cell GmbH (hereinafter Seller) warrants the goods to be free from defects in material and workmanship to the original purchaser. During the warranty period, Seller agrees to repair or replace defective and/or nonconforming goods or parts without charge for material or labor, or, at the Seller's option, demand return of the goods and tender repayment of the price. The buyer's exclusive remedy is repair or replacement of defective and nonconforming goods, or, at the Seller's option, the repayment of the price.

Seller excludes and disclaims any liability for lost profits, personal injury, interruption of service, or consequential incidental or special damages arising out of, resulting from, or relating in any manner to these goods.

This Limited Warranty does not cover defects, damage, or nonconformity resulting from abuse, misuse, neglect, lack of reasonable care, modification, or the attachment of improper devices to the goods. This Limited Warranty does not cover expendable items. This warranty is void when repairs are performed by a non-authorized person or service center. At the Seller's option, repairs or replacements will be made on-site or at the factory. If repairs or replacements are to be made at the factory, the Buyer shall return the goods prepaid and bear all the risks of loss until delivered to the factory. If Seller returns the goods, they will be delivered prepaid and Seller will bear all risks of loss until delivery to Buyer. Buyer and Seller agree that this Limited Warranty shall be governed by and construed by the laws of Germany.

The warranties contained in this agreement are in lieu of all other warranties expressed or implied, including the warranties of merchantability and fitness for a particular purpose.

This Limited Warranty supersedes all prior proposals or representations oral or written and constitutes the entire understanding regarding the warranties made by Seller to Buyer. This Limited Warranty may not be expanded or modified except in writing signed by the parties hereto.